

MEITRACK T711L GPS Vehicle Tracker

User Guide



Change History



File Name	MEITRACK T711L GPS Vehicle Tracker User Guide		
Project	T711L GPS vehicle tracker	Creation Date	2021-11-21
		Update Date	2022-09-21
Subproject	User Guide	Total Pages	18
Version	V1.3	Confidential	External Documentation

Contents

1 Copyright and Disclaimer.....	- 4 -
2 Product Introduction	- 4 -
2.1 Product Features.....	- 4 -
2.1.1 Harsh Acceleration, Harsh Braking, and Harsh Cornering Alerts.....	- 4 -
2.1.2 Setting the Output Port Status Based on Events.....	- 4 -
2.1.3 Idling Detection.....	- 4 -
2.1.4 Starting the Engine by iButton	- 5 -
3 Product Functions and Specifications	- 5 -
3.1 Product Functions	- 5 -
3.1.1 Position Tracking	- 5 -
3.1.2 Anti-Theft.....	- 5 -
3.1.3 Other Functions	- 5 -
3.2 Product Specifications	- 6 -
4 Main Device and Accessories	- 7 -
5 Product Appearance	- 8 -
6 First Use	- 8 -
6.1 Installing a SIM Card	- 8 -
6.2 LED Indicator.....	- 9 -
6.3 Device Configuration	- 9 -
6.3.1 Installing the USB Driver	- 9 -
6.3.2 Configuring Device Parameters by Meitrack Manager.....	- 10 -
6.4 Tracking by Mobile Phone.....	- 11 -
6.5 Common SMS Commands	- 12 -
6.5.1 Querying the Location in Real Time – A00.....	- 12 -
6.5.2 Controlling Output 1 Status by iButton – A17.....	- 12 -
6.5.3 Setting GPRS Parameters – A21	- 13 -
6.5.4 Setting the Idling Alert – B14	- 13 -
6.5.5 Setting the Harsh Acceleration or Harsh Braking Alert – BBD.....	- 14 -
6.5.6 Setting the Sharp Left Turn or Sharp Right Turn Alert – BC6.....	- 14 -
6.5.7 Controlling Output Status – C01	- 14 -
6.5.8 Setting I/O Port Status – C08	- 15 -
7 Logging In to MS03 Tracking System.....	- 16 -
8 Device Installation	- 16 -
8.1 Installing the I/O Port Cable.....	- 16 -
8.1.1 Interface Definition	- 16 -
8.1.2 Wiring	- 17 -
8.2 Mounting the Device	- 18 -

1 Copyright and Disclaimer

Copyright © 2022 MEITRACK. All rights reserved.

 ,  and  are trademarks that belong to Meitrack Group and its subsidiary.

The user manual may be changed without notice.

Without prior written consent of Meitrack Group, this user manual, or any part thereof, may not be reproduced for any purpose whatsoever, or transmitted in any form, either electronically or mechanically, including photocopying and recording.

Meitrack Group shall not be liable for direct, indirect, special, incidental, or consequential damages (including but not limited to economic losses, personal injuries, and loss of assets and property) caused by the use, inability, or illegality to use the product or documentation.

2 Product Introduction

The T711L is a GPS vehicle tracker featuring the IP67 water resistance rating and internal GPS and GSM antennas. This tracking unit can work properly in harsh environments. It is specially designed for different types of vehicles, such as cars, motorcycles, yachts, and boats.

2.1 Product Features

2.1.1 Harsh Acceleration, Harsh Braking, and Harsh Cornering Alerts

Users can set the thresholds of harsh acceleration, harsh braking, and harsh cornering alerts by using Meitrack Manager software, BBD command, or BC6 command.

Note: The alert results vary depending on the device installation, vehicle model, vehicle weight, and driving behaviors. After the device is installed properly, you can use the BBD command, BC6 command, or Meitrack Manager software to change the values of harsh acceleration, harsh braking, and harsh cornering alerts.

2.1.2 Setting the Output Port Status Based on Events

Users can control the output port status based on events.

For example:

1. When the device detects speeding, the buzzer makes sounds.
2. When the device detects unauthorized ignition or GPS antenna cut-off, the engine fails to be started.
3. When the device detects that the iButton reader is triggered, the engine starts.
4. When the device detects that an input is activated or inactivated, the output port is active or inactive.

2.1.3 Idling Detection

This function is used to detect whether a vehicle's engine is switched off while parking. To enable the function, input 1 must be connected to the ACC detection cable.

When the device detects that the ACC is on and the driving speed is 0 for one consecutive minute (default time), an idling alert is sent.

For details, see the section 6.5.4 "Setting the Idling Alert – B14."

2.1.4 Starting the Engine by iButton

After swiping the authorized iButton key, the driver must start the engine within one minute. Otherwise, the device's output 1 is triggered (engine cut-off), and thus the driver cannot start the vehicle. If you want to start the engine, you must swipe the iButton key again.

Before starting the engine, ensure that:

1. The device's input 1 is connected to the engine detection cable.
2. An iButton key has been authorized.
3. The device's output 1 is connected to the engine control cable through a relay.
4. The RFID ignition function has been enabled by Meitrack Manager or MS03 tracking platform.
5. The RFID event has been enabled on Meitrack Manager. Otherwise, the function is unavailable.

3 Product Functions and Specifications

3.1 Product Functions

3.1.1 Position Tracking

- GPS + LBS positioning
- Real-time location query
- Tracking by time interval
- Tracking by distance
- Tracking by mobile phone
- Speeding alert
- Cornering report

3.1.2 Anti-Theft

- Polygonal geo-fence
- Engine or vehicle door status alert
- Remote vehicle fuel or power cut-off
- GPS blind spot alert
- Towing alert

3.1.3 Other Functions

- SMS or GPRS (TCP or UDP) communication (Meitrack protocol)
- Built-in 8 MB flash for recording driving routes
- IP67 water resistance rating
- Mileage report
- Deep sleep mode
- Built-in 3-axis accelerometer
- GPS data filtering
- Stop Moving and Start Moving alerts
- Vehicle power protection
- Set the output port status based on events

- A-GPS
- Idling alert
- Harsh acceleration alert
- Harsh braking alert
- Harsh cornering alert
- Vehicle maintenance reminding
- Online Parameter Editor (MS03 platform)
- Support online OTA updates

3.2 Product Specifications

Item	Specifications
Dimension	75 mm x 44 mm x 17 mm
Weight	77g
I/O power cable length	50 cm
Power supply	DC 11.4–90 V/1.5 A
Power consumption	Current in standby mode: 65 mA
Operating temperature	-35°C to 80°C (for the device without a battery)
High temperature resistant battery	200mAh (Operating temperature: -5°C to 75°C)
Operating humidity	5%–95%
LED indicator	Green LED indicator showing the GSM signal Blue LED indicator showing the GPS signal
Button/Switch	1 upgrade button (used to manually upgrade the firmware) 1 power button
Memory	8 MB flash
Sensor	3-axis accelerometer
Frequency band	T711L: LTE FDD: B1/B3/B7/B8/B20/B28 LTE TDD: B38/B40 GSM: 900/1800
Bluetooth 2.4G	Internal Bluetooth module, compatible with Bluetooth 5.0 GHz
GPS sensitivity	-165 dB
GNSS	Dual-mode positioning (GPS/BeiDou/GLONASS)
Positioning accuracy	2.5 meters
I/O port	1 positive input by default (ACC) 1 analog detection input (0–30 V) 1 open collector 1 1-Wire port 1 debug interface (Micro USB)

4 Main Device and Accessories

Standard accessories:

- T711L vehicle tracker (with a cable of 50 cm in length)
- High temperature resistant battery (200 mAh)
- L wrench
- Hexagon screw
- CD download card

Optional accessories:

Optional Accessory	Description
USB cable	Standard Android cable
Relay (12 V/24 V)	It is connected to output 1 or the 1-Wire port (green cable), which needs to be set to output 2.
Buzzer	It is connected to output 1 or the 1-Wire port (green cable), which needs to be set to output 2.
A52 digital temperature sensor	It is connected to the 1-Wire port (green cable). An external 5 V power supply is required to supply power, or it is connected to A61 sensor box for more functions.
iButton reader	It is connected to the 1-Wire port (green cable).
A53 fuel level sensor (analog input voltage)	It is connected to analog input 1 (blue cable).
Bluetooth temperature and humidity sensor	Check temperature (-20°C to 55°C) and humidity (0% to 100% RH). (A maximum of four Bluetooth temperature and humidity sensors are supported.)
Bluetooth beacon	Detect the location of the tracker or Bluetooth beacon. (A maximum of 16 Bluetooth beacons are supported.)

5 Product Appearance

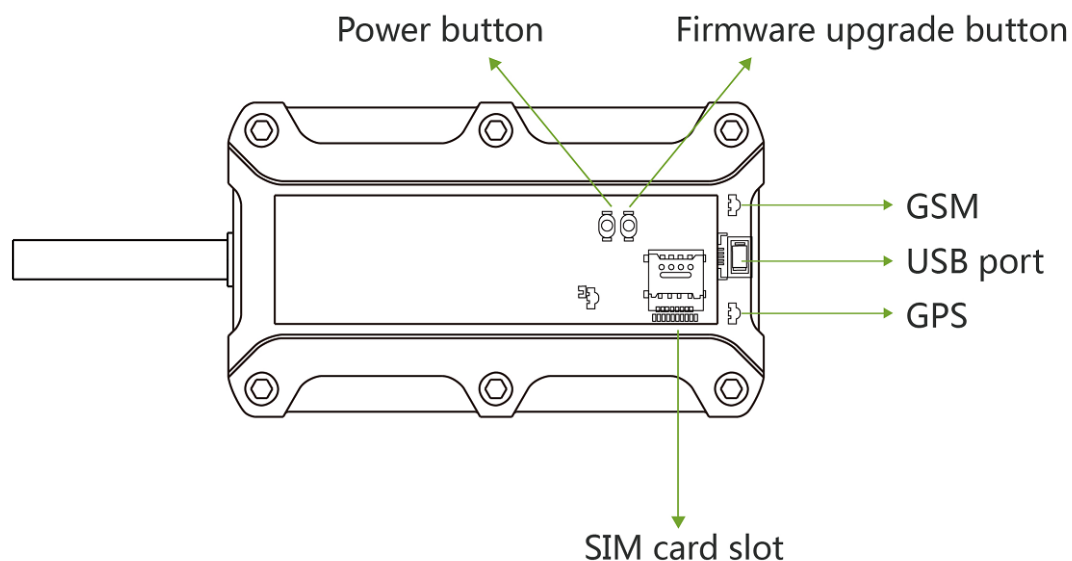

6 First Use

6.1 Installing a SIM Card

1. Installing the Nano-SIM

- 1 In the corner of the device, loosen the rubber covers and four screws to open the back cover.

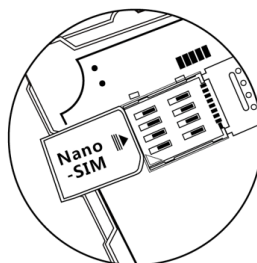
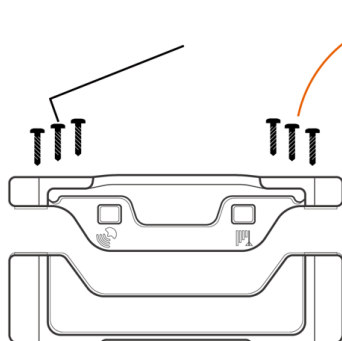

- 2 Insert the Nano-SIM into the card slot and close the back cover.

Perform the following steps to install a SIM card:

1. Use the screwdriver to open the back cover of the device.
2. Insert the nano-SIM card into the card slot (with the gold-plated contacts facing down).
3. Close the cover, and tighten the screws.

Note:

- Ensure that the SIM card has sufficient balance. (After the SIM card is installed properly, make calls and send SMS messages to confirm it.)
- Ensure that the PIN lock of the SIM card has been closed properly.
- Ensure that the SIM card in the device has subscribed the caller ID service if you want to use your authorized

phone numbers to call the device.

- Power off the device before installing the SIM card.

6.2 LED Indicator

To turn on the device, connect the device to an external power supply (12 V or 24 V) or press and hold down the power button for 3–5 seconds.

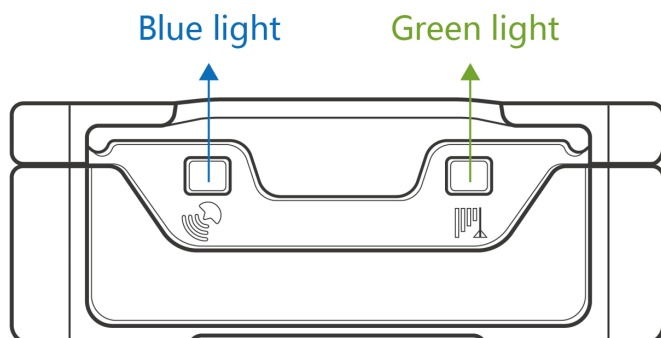

GPS LED Indicator (Blue)	
Blink fast (once every 0.1 seconds)	The device is being initialized, or the battery power is low.
Blink fast (0.1 seconds on and 2.9 seconds off)	A GPS signal is received.
Blink slowly (1 second on and 2 seconds off)	No GPS signal is received.
GSM LED Indicator (Green)	
Steady on	There is an incoming call.
Blink fast (once every 0.1 seconds)	The device is being initialized.
Blink fast (0.1 seconds on and 2.9 seconds off)	A signal is received from a base station.
Blink slowly (1 second on and 2 seconds off)	No signal is received from a base station.

6.3 Device Configuration

6.3.1 Installing the USB Driver

1. Decompress the **stsw-stm32102.zip** file provided by Meitrack, locate the following file, and install the USB driver on a computer with the 64-bit Windows system.

 VCP_V1.3.1_Setup_x64.exe

2. After the installation is finished, connect the device to the computer through the USB cable. If **STMicroelectronics Virtual COM Port (COM5)** is displayed on the **Device Manager** page, the driver is installed successfully.

Caution: Before connecting the device to the computer through the USB cable, turn on the device first. Otherwise, the device cannot be detected by Meitrack Manager.

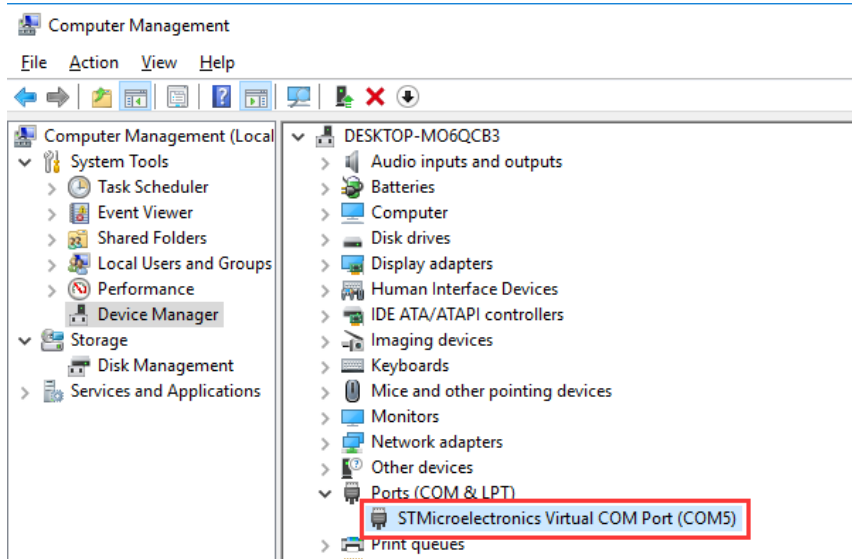

Note: After the driver installation is finished, if the preceding figure is not displayed, copy the **mdmcpq.inf** file to the **C:/windows/inf/** directory and **usbser.sys** file to the **C:/windows/system32/drivers/** directory, and then restart the computer.

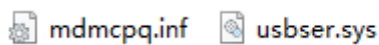

6.3.2 Configuring Device Parameters by Meitrack Manager

This section describes how to use Meitrack Manager to configure the device on a computer.

Operation steps:

1. Install the USB driver and Meitrack Manager.
2. Connect the device to a computer by using the USB cable, as shown in the following figure.

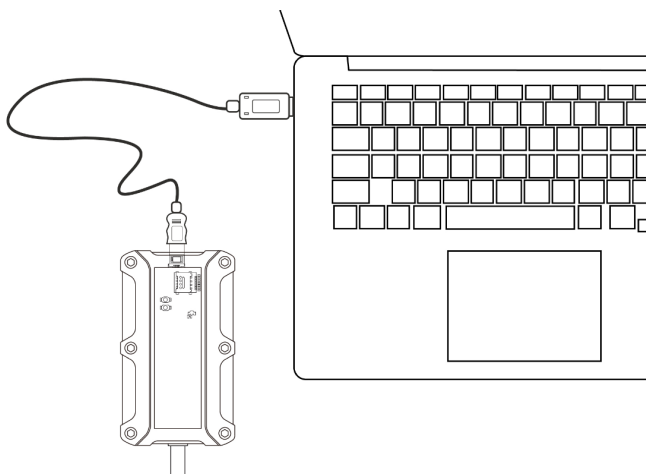

3. Run Meitrack Manager, then the following dialog box appears:



4. Turn on the device, then Meitrack Manager automatically detects the device model and the configuration interface (default parameter settings) appears accordingly.

For details about Meitrack Manager, see the *MEITRACK Manager User Guide*.

6.4 Tracking by Mobile Phone

Call or send the **0000,A00** command by SMS to the device's SIM card number. The device will reply to an SMS with a map link.

Click the SMS link. The device's location will be displayed on Google Maps on your mobile phone.

Note: Ensure that the device's SIM card number has subscribed the caller ID service. Otherwise, the tracking function by mobile phone is unavailable.

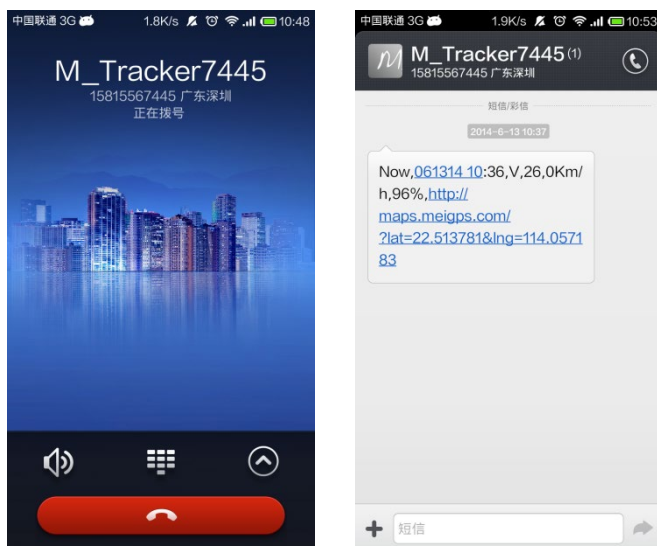

SMS example:

Now,061314 10:36,V,26,0Km/h,96%,http://maps.meigps.com/?lat=22.513781&lng=114.057183

The following table describes the SMS format:

Parameter	Description	Remarks
Now	Indicates the current location.	Alert type: indicates the current location or alert type.
061314 10:36	Indicates the date and time in MMDDYY hh:mm format.	Time
V	The GPS is invalid.	A = Valid V = Invalid
26	Indicates the GSM signal strength.	Value range: 1–32

		The larger the value is, the stronger the signal is. If the parameter value is greater than 12, it means that the GPRS signal strength is good.
0Km/h	The driving speed is 0.	Speed
96%	The remaining battery capacity is 96%.	Remaining battery capacity
http://maps.meigps.com/?lat=22.513781&lng=114.057183	This is a map link with a latitude and longitude. lat indicates the latitude. Latitude: 22.513781. lng indicates the longitude. Longitude: 114.057183.	You can visit the map through a mobile phone. lat indicates the latitude, and lng indicates the longitude.

If your mobile phone does not support HTTP, enter the latitude and longitude on Google Maps to query a location. (Note: The two digits placed before the decimal point are a latitude, and the three digits placed before the decimal point are a longitude.)

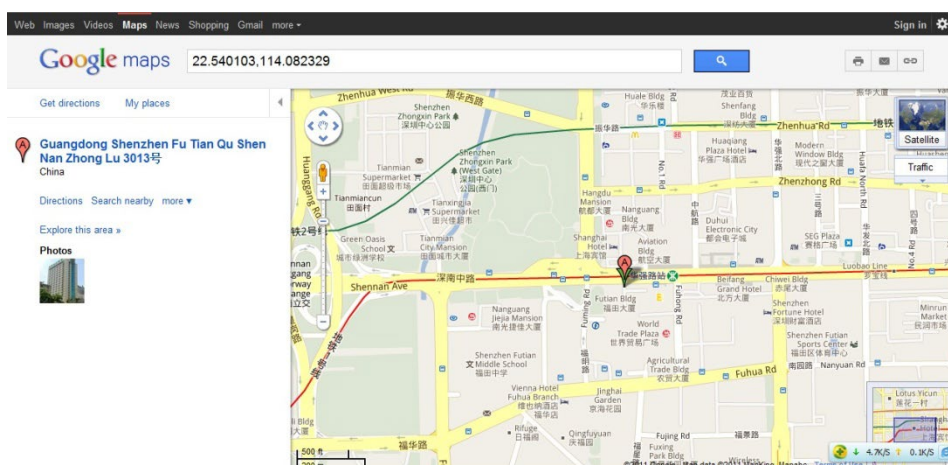

6.5 Common SMS Commands

6.5.1 Querying the Location in Real Time – A00

SMS sending: 0000,A00

SMS reply: Now,Date and time,Positioning status,GSM signal strength,Speed,Remaining battery capacity,Map link

Description: This command is used to query the current location of the device.

Example:

SMS sending: 0000,A00

SMS reply: Now,160721 16:40,V,12,56Km/h,97%,<http://maps.meigps.com/?lat=22.513015&lng=114.057235>

6.5.2 Controlling Output 1 Status by iButton – A17

SMS sending: 0000,A17,X

SMS reply: IMEI,A17,OK

Description:

X = 1: function enabled. Before using the function, you must ensure: 1. ACC detection is connected to input 1; 2. An iButton key has been authorized.

X = 0: function disabled (default).

For example, after swiping the authorized iButton key, you must start the engine (input 1 is connected to engine detection) within one minute. If the time exceeds one minute, you need to swipe the iButton key again. After the engine is started, input 1 will always detect the ACC status. If ACC ON is detected (that is, input 1 is the high level), output 1 will not generate data. If ACC OFF is detected, wait for one minute and then swipe the authorized iButton key to start the engine as required.

Example:

SMS sending: 0000,A17,0

SMS reply: 353358017784062,A17,OK

6.5.3 Setting GPRS Parameters – A21

SMS sending: 0000,A21,*Connection mode,IP address,Port,APN,APN user name,APN password*

SMS reply: IMEI, A21,OK

Description:

Connection mode = 0: function disabled.

Connection mode = 1: function enabled. Use the TCP/IP reporting mode.

Connection mode = 2: function enabled. Use the UDP reporting mode.

IP address: IP address or domain name. Contains a maximum of 32 bytes.

Port: contains a maximum of 5 digits.

APN/APN user name/APN password: contains a maximum of 32 bytes respectively. If no user name and password are required, leave them blank.

Example:

SMS sending: 0000,A21,1,server.meigps.com,8800 ,CMNET,,

SMS reply: 353358017784062,A21,OK

6.5.4 Setting the Idling Alert – B14

SMS sending: 0000,B14,*Consecutive time (second),Speed (km/h),Alert Time (second)*

SMS reply: IMEI,B14,OK

Description:

This command is used to detect whether an idling alert is generated. The device's input 1 must be connected to ACC detection. Otherwise, the function is unavailable.

Consecutive time and alert time: indicate the consecutive time for the speed and alert time respectively. The value of the two parameters ranges from **0** to **60000**. Unit: second.

Speed: The parameter value ranges from **0** to **200**. Unit: km/h. (Recommended value: 5 km/h)

An idling alert is generated when the following conditions are met simultaneously: the device detects that the ACC is on, the driving speed is smaller than the preset value, and the consecutive time for the speed is larger than the preset value.

If you want to read the command settings, send **0000,B14**.

Note: The alert activation conditions may be affected due to static drift. Therefore, it is recommended that you should set the speed to a value between 5 km to 10 km and the consecutive time for the speed to a value that is larger than

60 seconds. The alert time is unavailable temporarily. It is recommended that you should set this parameter to **0**.

Example:

SMS sending: 0000,B14,60,5,0

SMS reply: 353358017784062,B14,OK

6.5.5 Setting the Harsh Acceleration or Harsh Braking Alert – BBD

SMS sending: 0000,BBD,X1,Y1,Z1,X2,Y2,Z2

SMS reply: IMEI,BBD,OK/<Error code>

Description:

X1: indicates the initial speed after the vehicle accelerates suddenly. Unit: km/h. The maximum parameter value is **480**.

Y1: indicates the increased speed after the vehicle accelerates suddenly. Unit: km/hr/sec. The parameter value ranges from **0** to **1000**.

Z1: indicates the detection time of the harsh acceleration alert. Unit: second. The parameter value ranges from **1** to **255**.

X2: indicates the initial speed after the driver brakes sharply. Unit: km/h. The maximum parameter value is **480**.

Y2: indicates the increased speed after the driver brakes sharply. Unit: km/hr/sec. The parameter value ranges from **-1000** to **0**.

Z2: indicates the detection time of the harsh braking alert. Unit: second. The parameter value ranges from **1** to **255**.

If you want to read the command settings, send **0000,BBD**.

Example:

SMS sending: 0000,BBD,200,100,10,200,-100,10

SMS reply: 353358017784062,BBD,OK

6.5.6 Setting the Sharp Left Turn or Sharp Right Turn Alert – BC6

SMS sending: 0000,BC6,A,B,C

SMS reply: IMEI,BC6,OK/<Error code>

Description:

A: indicates the angle. The parameter value ranges from **0** to **359**.

B: indicates the consecutive cornering time. The parameter value ranges from **2** to **100**. Unit: second.

C: indicates the driving speed. The parameter value ranges from **0** to **255**. Unit: km/h.

If you want to read the command settings, send **0000,BC6**.

Example:

SMS sending: 0000,BC6,90,10,60

SMS reply: 353358017784062,BC6,OK

6.5.7 Controlling Output Status – C01

SMS sending: 0000,C01,Speed,ABCDE

SMS reply: IMEI,C01,OK

Description:

Speed = 0: No speed limit exists. When the device receives the command, the function takes effect immediately.

Speed = [1...255]: Set the speed limit. Unit: km/h. When the driving speed is lower than the speed limit, the function takes effect.

ABCDE: indicate outputs 1–5 respectively. When the parameter value is **0**, the output is disabled. When the parameter value is **1**, data is generated according to the preset output mode. When the parameter value is **2**, the previous status

remains unchanged.

Example:

SMS sending: 0000,C01,10,10000

SMS reply: 353358017784062,C01,OK

6.5.8 Setting I/O Port Status – C08

SMS sending: 0000,C08,IO0:Mn,IO1:Mn,IO2:Mn,IO3:Mn,IO4:Mn

SMS reply: IMEI,C08,IO0:Mn,IO1:Mn,IO2:Mn,IO3:Mn,IO4:Mn

Description:

1. **IO0, IO1, IO2, and IO3** indicate I/O ports.
 - IO0: open collector 1 by default (yellow cable: output 1)
 - IO1: 1-Wire port by default (green cable)
 - IO2: positive input 1 by default (white cable)
 - IO3: analog input 1 by default (blue cable)
2. **Mn** indicates the I/O port status. The parameter value is as follows:
 - 0: low trigger
 - 1: high trigger
 - 2: analog input
 - 4: open collector
 - 5: low output
 - 6: PWM output
 - 8: 1-Wire
3. You can set one or multiple input ports simultaneously. If you want to read the command settings, send **0000,C08**.

Note:

1. IO0: The parameter value of **Mn** is **4, 5, or 6**.
2. IO1: The parameter value of **Mn** is **0, 4, 5, 6, or 8**.
3. IO2: The parameter value of **Mn** is **0 or 1**.
4. IO3: The parameter value of **Mn** is **0, 1, or 2**.

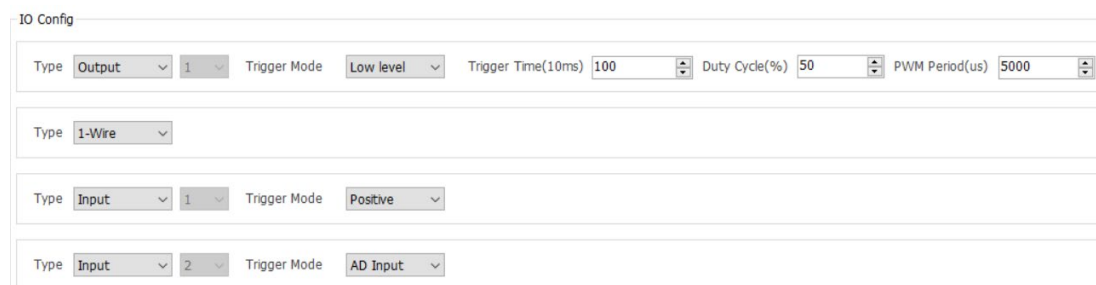

The screenshot shows the 'IO Config' interface with the following settings:

- Port 1: Type: Output, Mn: 1, Trigger Mode: Low level, Trigger Time(10ms): 100, Duty Cycle(%): 50, PWM Period(us): 5000
- Port 2: Type: 1-Wire
- Port 3: Type: Input, Mn: 1, Trigger Mode: Positive
- Port 4: Type: Input, Mn: 2, Trigger Mode: AD Input

Example:

SMS sending: 0000,C08

SMS reply: 353358017784062,C08,IO0:5,IO1:8,IO2:1,IO3:2

For details about SMS commands, see the *MEITRACK SMS Protocol*.

Note:

1. The default SMS command password is 0000. You can change the password by using Meitrack Manager or an SMS command.
2. The device can be configured by an SMS command with a correct password. After an authorized phone number

is set, only the authorized phone number can receive the preset SMS event report.

7 Logging In to MS03 Tracking System

Visit <http://ms03.trackingmate.com>, enter the user name and password, and log in to the MS03. (Purchase the login account from your provider.)

For more information about how to add a device, see the *MEITRACK MS03 GPS Tracking System User Guide* (chapter 4 "Getting Started").

The MS03 platform supports the following functions:

- Track by time interval or distance.
- Query historical trips.
- Set polygonal geo-fences.
- Bind driver and vehicle information.
- View different types of reports.
- Send commands in batches.
- Support OTA updates.

For details, see the *MEITRACK MS03 GPS Tracking System User Guide*.

8 Device Installation

8.1 Installing the I/O Port Cable

8.1.1 Interface Definition

The I/O port cable of the device is a 6-pin cable, including the power port, analog input port, positive input port, negative input port, output port, and 1-Wire port.



1	2	3	4	5	6
Power (+)	GND (-)	Input 1 (+)	Output 1	Analog input 1	1-Wire port

Pin Number	Cable Color	Description
1 (Power +)	Red	Positive charge of the power input. Connect to the positive charge of the vehicle battery. Input voltage: 11.4–90 V. 12 V or 24 V is recommended.
2 (GND)	Black	Ground wire. Connect to the negative charge of the vehicle battery or to the negative terminal.

3 (Input 1)	White	Digital input (positive trigger). The port can be configured as the negative trigger. Connect to the vehicle's ACC cable by default to detect the vehicle's ACC status.
4 (Output 1)	Yellow	Valid: low level (0 V) Invalid: open collector Maximum voltage for the open collector output (invalid): 60 V Maximum current for the low level output (valid): 500 mA Set the PWM output (adjustable output time and pulse width). Connect to an external relay to remotely cut off the vehicle fuel cable or engine power supply.
5 (Analog input 1)	Blue	Analog input with 12-bit resolution. Valid voltage: 0–30 V. The port can be configured as negative input 2.
6 (1-Wire port)	Green	Connect to the iButton reader and other devices supporting the 1-Wire protocol. The port can be configured as negative input 3 or open collector output 2.

8.1.2 Wiring

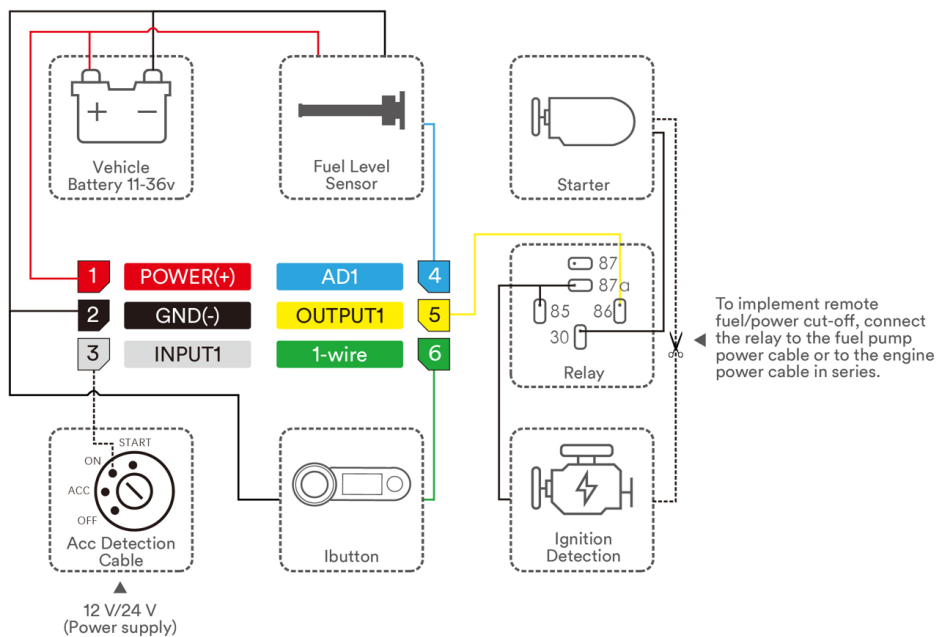

8.2 Mounting the Device

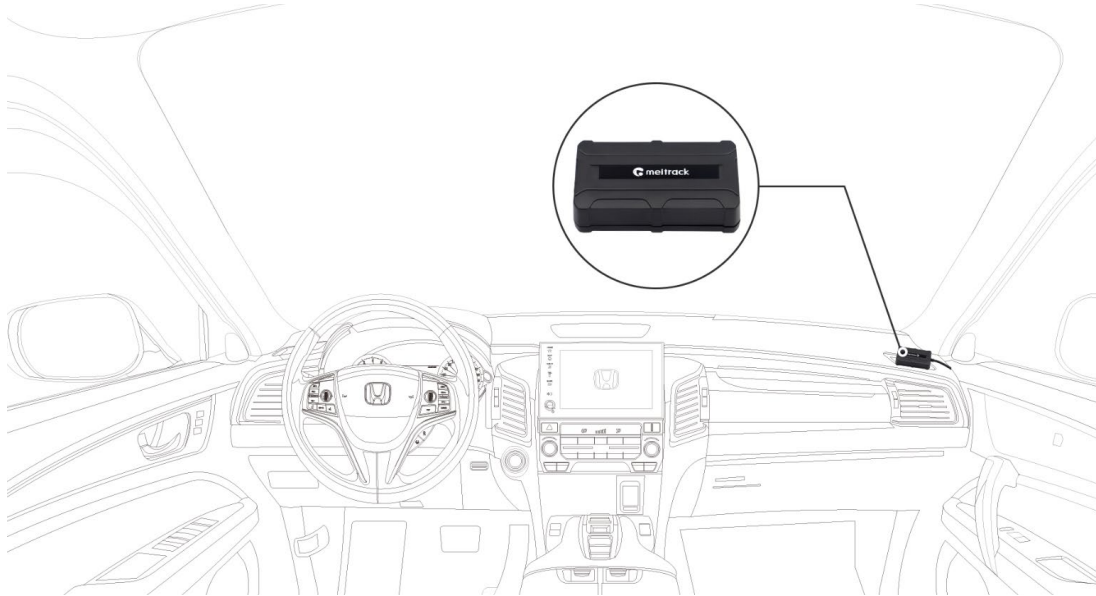

Mount the device in the vehicle by a cable tie or 3M double-sided tape.

Note: Do not install it at a metal covered place.

If you have any questions, do not hesitate to email us at info@meitrack.com.