

iStartek 4G Vehicle GPS Tracker VT200-L User Manual V1.3



Content

1. Copyright and Disclaimer.....	3
2. Product Description.....	3
3. Product Function.....	3
4. Product Specification.....	4
5. Products and accessories.....	5
5.1 Standard accessories.....	5
5.2 Optional accessories.....	6
6. Product Appearance.....	7
7. Product Operation.....	7
7.1 Recharge.....	7
7.2 Install SIM card.....	7
7.3 Turn on Device.....	8
7.4 Track by SMS.....	8
7.5 Parameter configuration.....	9
7.6 Track by GPS Tracking Platform.....	9
8. Product Installation.....	10
8.1 Power Cable Function Introduction.....	10
8.2. Device and Accessories Wire Connection.....	11
8.2.1 Power/Ground Wire Connection.....	12
8.2.2 Digital inputs installation.....	12
8.2.3 Analog Input Installation.....	13
8.2.4 Output Control Wire Installation.....	15
8.2.5 Temperature Sensor Installation.....	16
8.2.6 RFID Reader Installation.....	16
8.2.7 iButton Installation.....	18
8.2.8 Ultrasonic Fuel Sensor Installation.....	19
8.2.9 OBD Reader Installation.....	21
8.2.10 Speed limiter installation.....	21

1. Copyright and Disclaimer

Shenzhen iStartek Technology Co., Ltd. All rights reserved Copyright © 2021 iStartek.

iStartek and  are registered trademarks of Shenzhen iStartek Technology Co., Ltd.

This manual cannot be copied for any purpose, disseminated in any way without the written authorization of iStartek.

iStartek shall not be liable for direct, indirect or all losses (including but not limited to economic losses, personal injuries, property and assets) caused by the use or inappropriate use of the product or documents.

2. Product Description

VT200-L is a 4G based GPS vehicle tracker. With built-in high-precision GPS positioning module reports the vehicle location and vehicle status to the vehicle tracking service platform through the 4G network for real-time vehicle monitoring, anti-theft, and dispatch management. It can be applied to fleet management, public transportation management, school bus management, taxi operation management, vehicle insurance company management, leasing management and private car anti-theft, etc.

VT200-L has a built-in 128Mb Flash memory. When the device enters blind area, it will automatically save historical positioning data. When the network recover, it will automatically resend historical positioning data to the service platform.

VT200-L contains an RS232 port, which can be connected to RFID to perform identity recognition and vehicle control for vehicle drivers; It can also be connected to OBD reader to read car ECU data and other RS232 peripherals to achieve corresponding functions.

3. Product Function

- ◇ GPS+GSM base station dual-mode positioning
- ◇ Real-time tracking
- ◇ Track by time interval
- ◇ Track by distance
- ◇ Heading change report
- ◇ Mileage report
- ◇ External power failure alarm
- ◇ SMS alarm
- ◇ SOS alarm
- ◇ Low battery alarm
- ◇ Engine and door status change alarm
- ◇ Support dual servers
- ◇ Geo-fence alarm
- ◇ Speeding alarm
- ◇ GPS signal loss alarm

- ✧ Harsh acceleration alarm
- ✧ Harsh deceleration alarm
- ✧ Harsh turning alarm
- ✧ Impact alarm
- ✧ Vibration (towing) alarm
- ✧ Idling alarm
- ✧ Fatigue driving alarm
- ✧ Fuel theft alarm
- ✧ Low fuel alarm
- ✧ High and low temperature alarm
- ✧ 128 Mb Flash
- ✧ FOTA upgrade
- ✧ Set ACC ON, ACC OFF time interval
- ✧ Remote control fuel/electricity
- ✧ RFID, iButton driver identification (optional)
- ✧ Buzzer alarm (optional)
- ✧ Fuel sensor (optional)
- ✧ Temperature sensor (optional)
- ✧ OBD reader (optional)

4. Product Specification

Item	Specification
Size	99 x 54 x 19.5mm
Weight	106g
Input voltage	DC 9 - 100V/1.5A
Waterproof level	IP66
Inbuilt Battery	500mAh/3.7V (High temperature resistant battery)
Average standby power consumption	110mA/h
Operating hours	33hours in power saving mode and 4.5 hours in normal working mode
Working temperature	-20°Cto 80°C
Working humidity	5% to 95%
LTE/WCDMA/GSM Bands	VT200-LCN: LTE-FDD: B1/B3/B5/B8 LTE-TDD: B34/B38/B39/B40/B41 GSM: 900/1800MHz VT200-LEU LTE-FDD: B1/B3/B5/B7/B8/B20/B28 LTE-TDD: B38/B40/B41 GSM: 850/900/1800/1900MHz

	VT200-LAU LTE-FDD: B1/B2/B3/B4/B5/B7/B8/B28/B66 LTE-TDD: B40 WCDMA: B1/B2/B4/B5/B8 GSM: 850/900/1800/1900MHz
GPS Sensitivity	-165dB
Positioning accuracy	2.5 meter
LED Indicator	2 LED lights indicate GPS/GSM status
GSM antenna	Built-in FPC
GPS antenna	Built-in ceramic antenna (25 X 25 X 4mm)
Flash	128M bit
Sensor	3D accelerometer
Switch	External toggle switch
SIM card	Nano SIM card, external push-push type
I/O	3 Digital inputs (Can be configured as high and low level trigger mode, Input3 can be configured as AD mode) 1 Analog input (0~36V) 2 Outputs 1 1-wire 1 RS232 1 5V output wire 1 Micro USB 1 Speaker 1 Microphone

5. Products and accessories

5.1 Standard accessories



Main Unit

5.2 Optional accessories



RFID Card Reader



RFID Tag



iButton Reader



iButton



Ultrasonic Fuel Sensor



Capacitive Fuel Sensor



Temperature Sensor



12V/24V Relay



OBD Reader



USB Cable



Buzzer



Speaker



Microphone



SOS Button

6. Product Appearance



7. Product Operation

7.1 Recharge

When using V200 L for the first time, please connect the tracker's red wire (positive) and black (ground wire) to a 12V or 24V power supply and charge for at least 2 hours to ensure sufficient power. After configuration and testing are completed, install it on the vehicle.

7.2 Install SIM card

The device supports 2G/3G/4G SIM card;

Please make sure that the SIM card has sufficient balance, the GPRS function has been activated and the correct APN of the SIM card has been confirmed;

Please make sure that the PIN lock function of the SIM card is turned off;

If you need to use the function: Call to reply location, please make sure that the SIM card has the caller ID display function;

Please make sure the device is turned off before installing SIM.

- Remove the waterproof rubber plug;
- Install the SIM card in the correct direction.



7.3 Turn on Device

Switch ON device or connect to external power supply, V200 L will start up and run.

LED lights indicate operating conditions:

GPS Indicator (Blue)	
OFF	Power OFF or in sleep mode
Flash (every 0.1 sec)	GPS module is starting or restarting
Fast Flash (0.1 sec ON, 2.9 sec OFF)	GPS signal received
Slow Flash (1sec ON, 2 Sec OFF)	No GPS signal
GSM Indicator (Green)	
ON	There is an incoming call or is in a call
OFF	Device is OFF or in sleep mode
Fast Flash (every 0.1 sec)	GSM module is starting or restarting
Fast Flash(0.1 sec ON, 2.9 sec OFF)	GSM signal received
Slow Flash (1sec ON, 2 Sec OFF)	No GSM signal

7.4 Track by SMS

Send SMS command to VT200-L:

0000,800

You will receive a text message with a link to Google maps. Click to open the link to display the current location on Google maps.

Please refer to "iStartek GPS Tracker Communication Protocol V1.3" for the description of SMS content and more SMS commands

7.5 Parameter configuration

Download and install the USB cable driver "PL2303_Prolific_Driver".

After the device is turned on, connect the VT200-L to the computer via a USB cable, run the "iStartek Parameter Editor_V1.01" configuration software and open the port to enter the parameter configuration state.

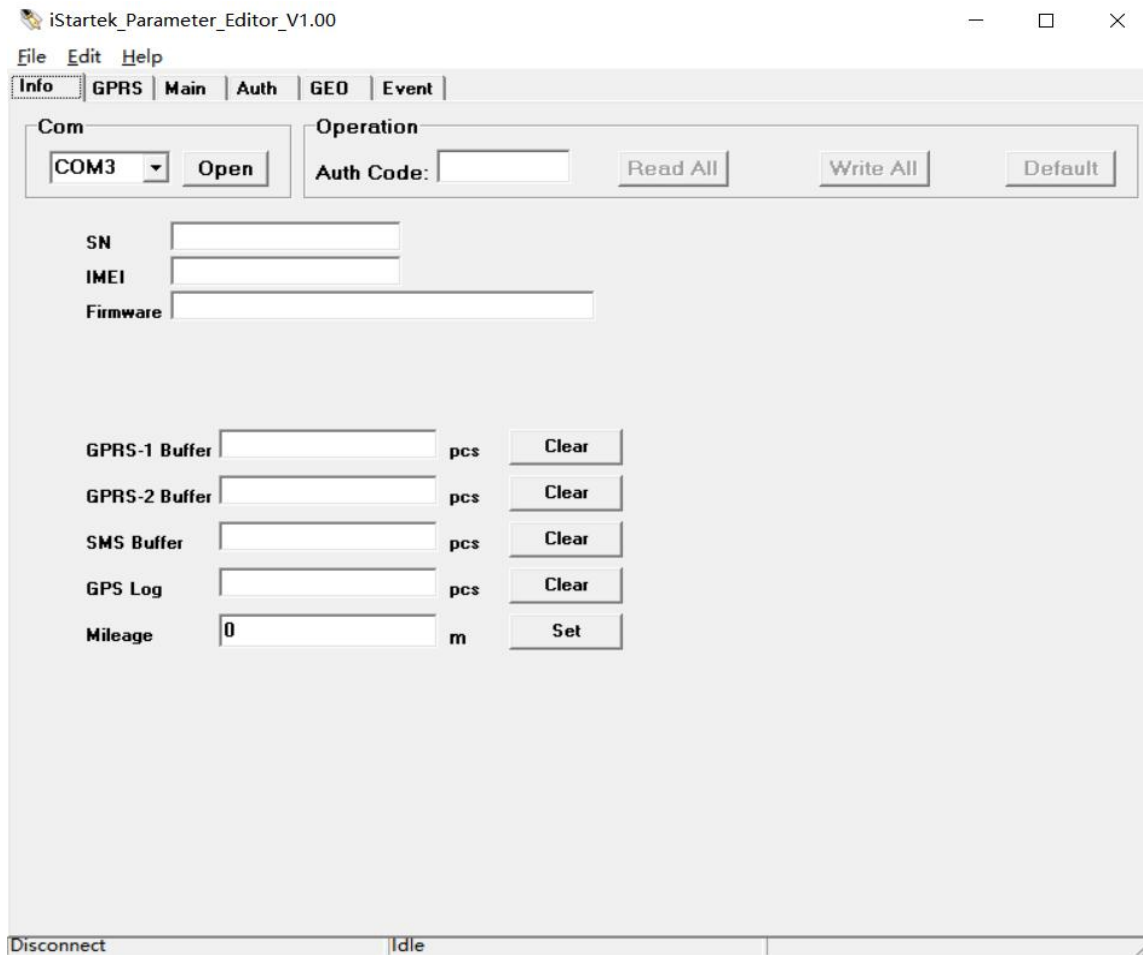

For more parameter configuration, please refer to "iStartek Parameter Editor User Manual V1.5".

7.6 Track by GPS Tracking Platform

1. You can set the server IP, Port, and APN parameters through SMS commands **100, 102, and 109**, and you can also use the iStartek Parameter Editor software to configure related parameters.
2. Check the parameters of commands 100, 101, 102, 105, 106, and 109 through SMS command 808, and you can also use iStartek Parameter Editor software to configure related parameters.

For more SMS command functions and parameter configuration, please refer to "iStartek GPS tracker Communication Protocol V1.3" and "iStartek Parameter Editor User Manual V1.5".

8. Product Installation

8.1 Power Cable Function Introduction

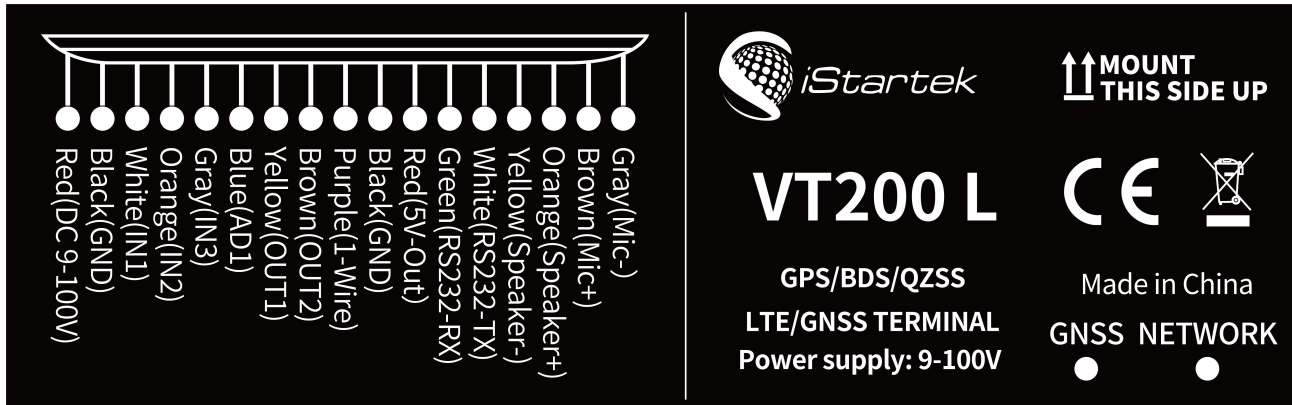

PIN	Color	Function
DC	Red	DC In (power input), connect to the positive pole of the car battery. Input voltage: 9V~36V. 12V/24V suggested.
GND	Black	GND, connect to the negative pole of the car battery, or to the iron place on the car.
IN1	Whit	Digital input 1, default is negative trigger. Positive and negative trigger can be configured by Parameter Editor. Used to connect to the SOS button.
IN2	Orange	Digital input 2, default is positive trigger. Positive and negative trigger can be configured by Parameter Editor; Used for ACC detection.
IN3	Grey	Digital input 3, default is positive trigger. Can configure positive and negative trigger or AD2 input (0-6.6V, 12-bit precision) by Parameter Editor.
AD1	Blue	AD1 input, positive trigger and AD1 input (0-36V, 12-bit precision) can be configured by Parameter Editor.
OUT1	Yellow	Open-drain output, drive capacity greater than 500MA; An external relay can be connected to remotely cut off the car's fuel/engine power supply, etc.
OUT2	Brown	Open-drain output, drive capacity greater than 500MA; Can connect an external buzzer to alarm, etc.
1-wire	Purple	Digital, can be connected to iButton and temperature sensor, can support up to 8 temperature sensors.
GND	Black	GND
5V	Red	DC 5V output, available for temperature sensor and serial port accessories.
RX	Green	RS232 RX
TX	White	RS232 TX
Speaker-	Yellow	External speaker, two-way conversation.

Speaker+	Orange	External MIC, two-way conversation or listening.
Mic+	Brown	
Mic-	Grey	

8.2. Device and Accessories Wire Connection

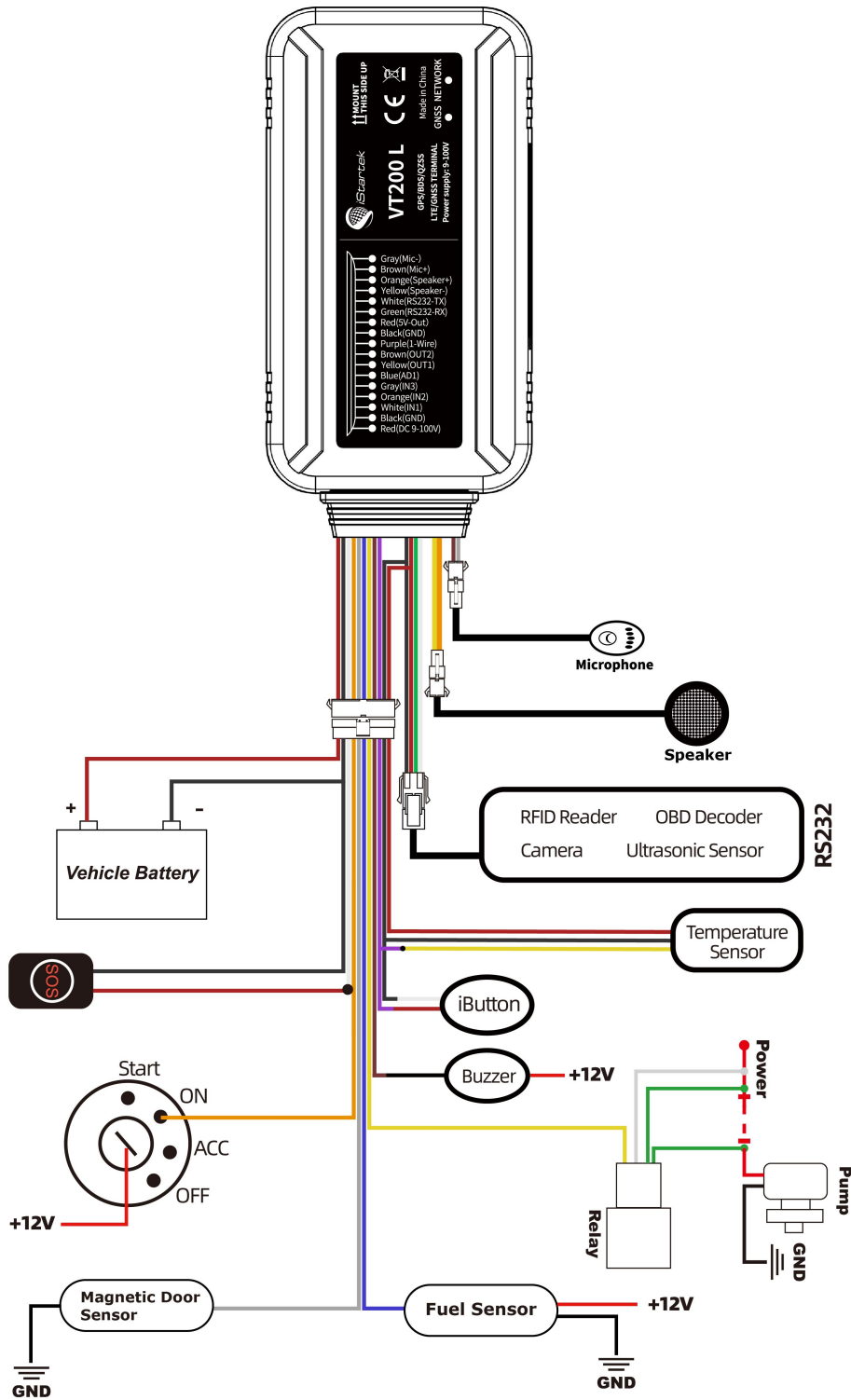

8.2.1 Power/Ground Wire Connection

Connect the red power wire and black ground wire to the positive and negative pole of the car battery to get power supply:

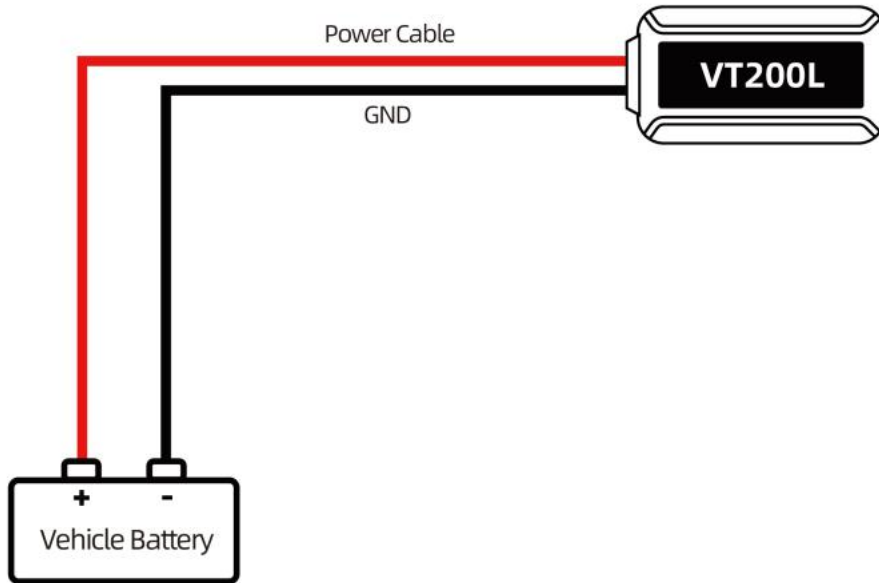

8.2.2 Digital inputs installation

Input2 can be connected to the vehicle ignition to detect ignition status.
Input1 or Input3 can be connected to the car door to detect the state.

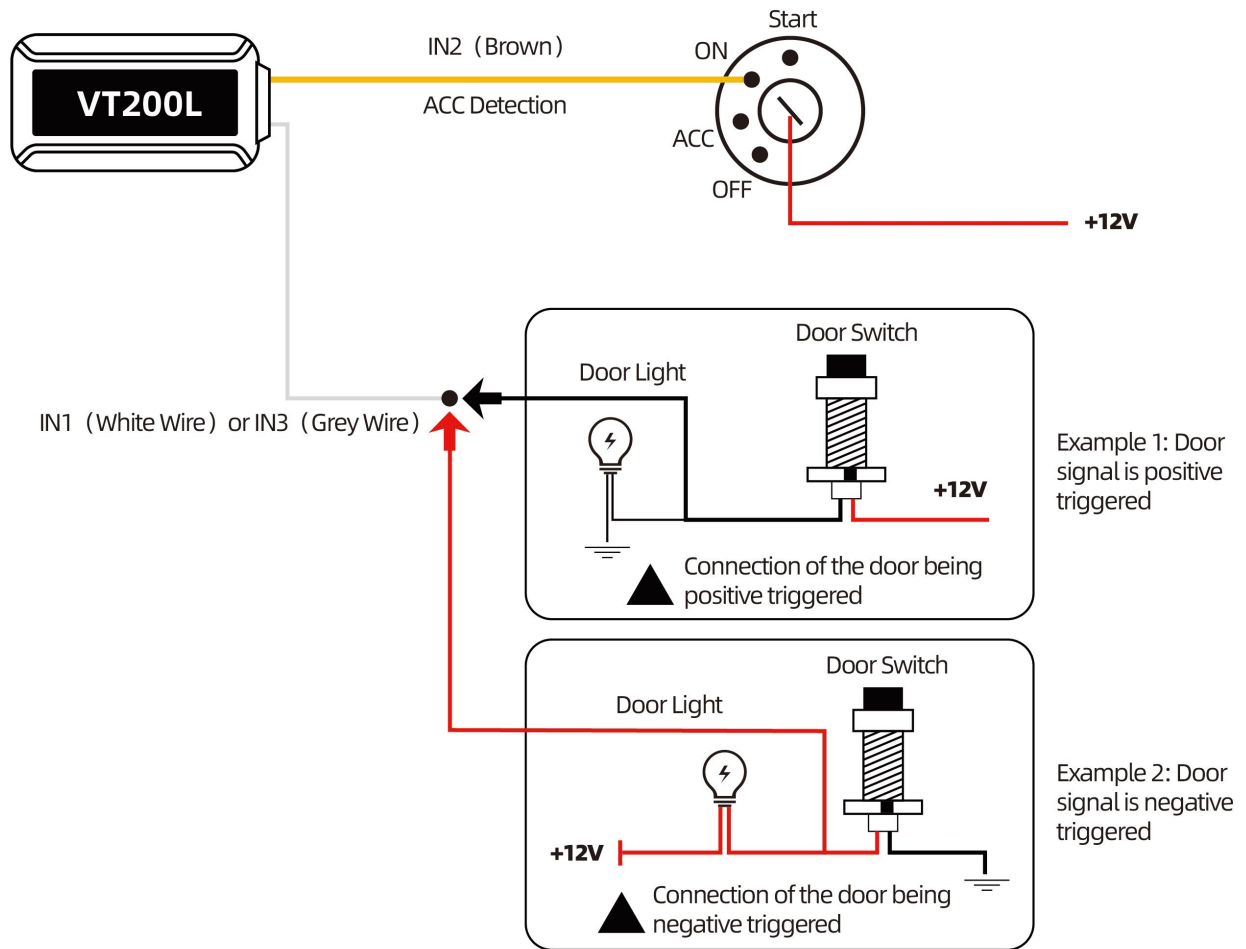

8.2.3 Analog Input Installation

The range of analog input AD1 is 0-36V, and the range of AD2 is 0-6.6V. Two voltage output sensors such as fuel sensors can be connected. The wiring connection is as follows:

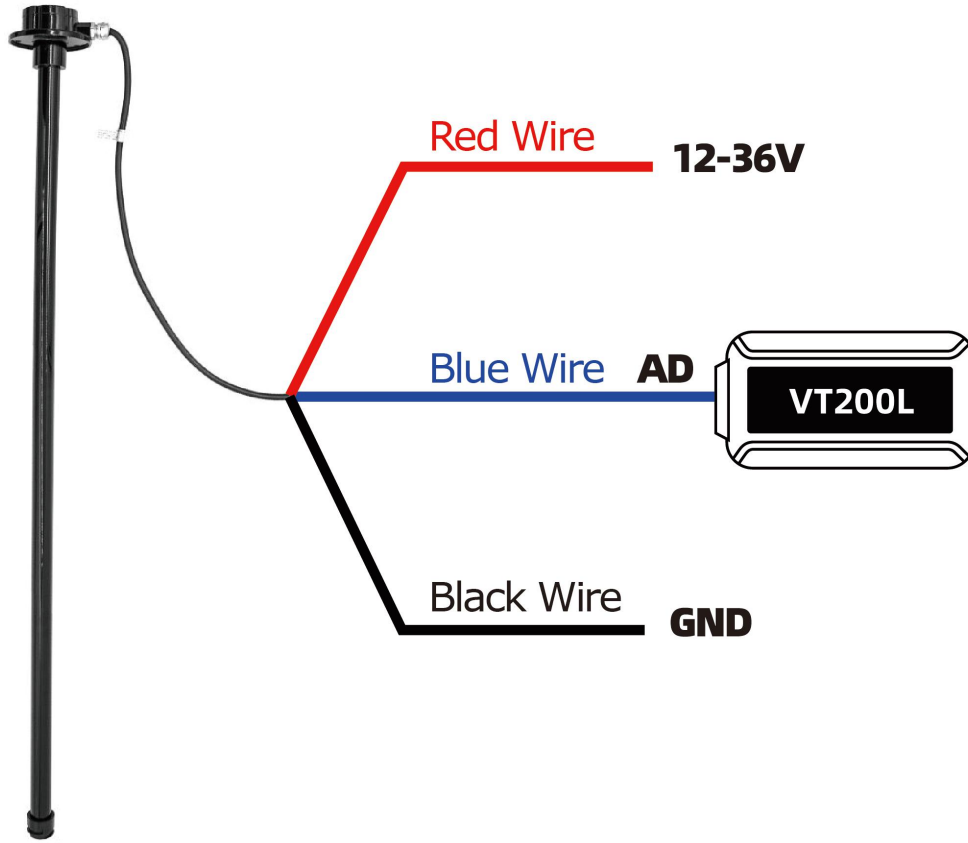

After connected wires, can set the size of the fuel tank (length, width, height), sensor type (capacitive fuel sensor or ultrasonic fuel sensor), liters of fuel stolen, fuel stolen time, low fuel alarm by Parameter Editor.

Info	GPRS	Main	Auth	GE0	Event
GPS Log Interval	0	second			
Distance Interval	0	meter			
Heading Change	0	degree			
Heartbeat Interval	60	minute			
Speeding	0	km/h			
Sleep Mode	Close				
Period Time Enter Sleep	0	second			
Vibration Sensitivity	3				
Tow Time	0	second			
Tow Mode	ACC Off and Tremble				
Idle Time	0	minute			
Low Ext-Bat	11.40	volt			
Harsh Accelerate	450	mg			
Harsh Braking	800	mg			
Harsh Turning	19				
Impact Sensitivity	5				
Fatigue Driving	0	minute			
Fatigue Relieve	0	minute			
Overtime Driving	0	minute			
GSM Jammed	0	second			

Input Mode		Active Time	
Input1	Low Active	0	ms
Input2	High Active	0	ms
Input3(AD2)	High Active	0	ms
Input4(AD1)	High Active	0	ms

Tank1 (AD1)			
Name	Right Tank	Sensor Type	Stick
Length	1000 mm	Steal	20 Liter
Wide	500 mm	Steal Time	60 second
High	1000 mm	Low Fuel	10 Liter

Tank2 (AD2)			
Name	Left Tank	Sensor Type	No Sensor
Length	0 mm	Steal	0 Liter
Wide	0 mm	Steal Time	0 second
High	0 mm	Low Fuel	0 Liter

For example, as above parameters setting, if the fuel tank connected to AD1 decreases more than 20 liters within 60 seconds, an fuel theft alarm will be generated; and if the fuel volume is less than 10 liters, a low fuel alarm will be generated.

Example: The fuel tank height is 100cm and full fuel is 50 liters, GPRS data as below:

&&A147,021104023195429,000,0,,180106093046,A,22.646430,114.065730,8,0.9,54,86,76,326781,460|0|27B3|0EA7,27,0000000F,02,01,04E2|018C|01C8 |0000,1,0104B0,01013D|02813546\r\n

AD1 voltage is **0x01C8** (hexadecimal)=456 (decimal), **AD1=456/100** (fixed value)=4.56V;

AD2 voltage is **0x0000=0**, **AD2=0/100=0V**;

Example: Connect the GPS Tracker analog input to capacitive fuel sensor, the yellow-green wire of the sensor are connected to the blue wires (AD) of the VT200-L.

When the fuel is empty, the sensor output voltage is 0V, when the fuel is full, the sensor output voltage is 5V

Calculate the percentage of remaining fuel:

Fuel percentage=(AD/5)*100%=(4.56/5)*100%=91.2%.

Calculate the remaining fuel in liters:

The remaining fuel in liters = **(AD/5) * 50 liters = 45.6 liters**

8.2.4 Output Control Wire Installation

The output wire can be connected to an external relay to cut off fuel/electricity and control the vehicle. You can also connect the buzzer to alarm.

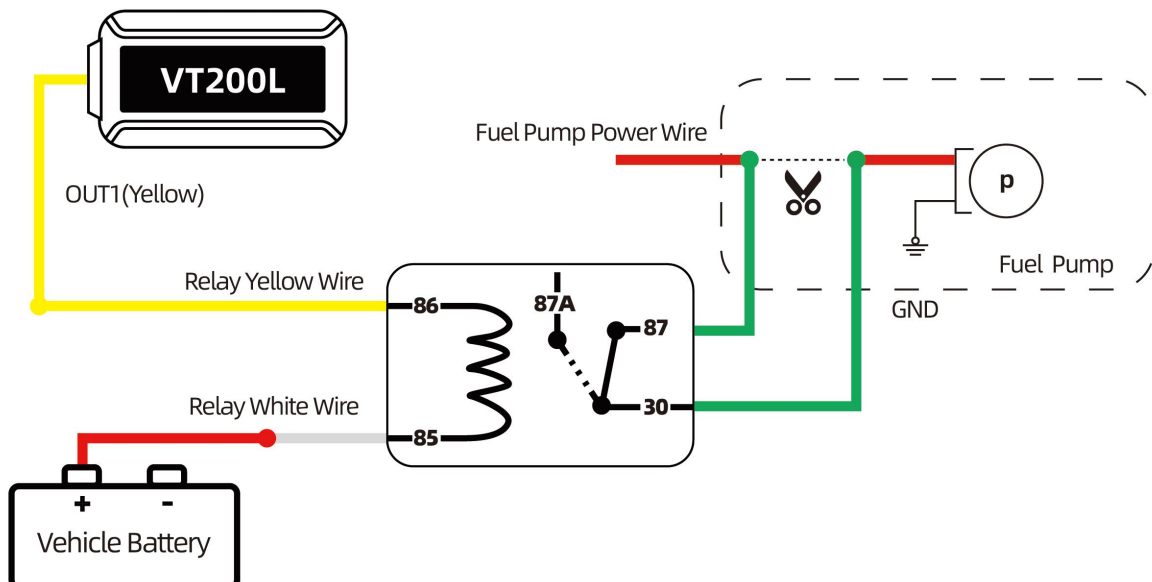

8.2.5 Temperature Sensor Installation

Connect device to a temperature sensor, the wiring connection is as below:

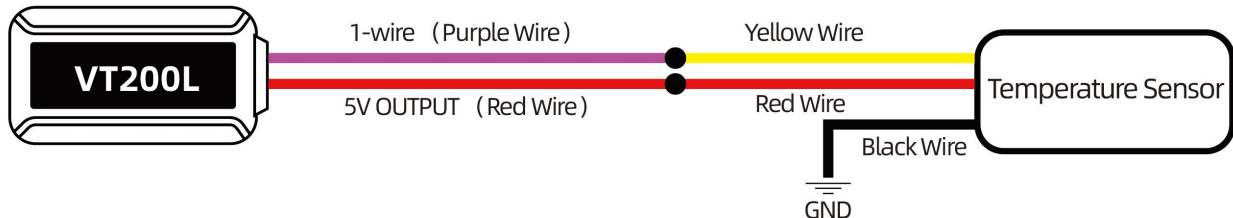

After connected wires, the temperature sensor can be configured through SMS commands, set high and low temperature alarms, and collect temperature value. For related parameter setting instructions, please refer to "iStartek GPS tracker Communication Protocol V1.3".

Example: after connected a temperature sensor as shown above,

1) Configure temperature sensor, can send command: 0000,135,1,Storage room

Description: 1 is the serial number of the temperature sensor, and Storage room is the name of the temperature sensor.

2) Set high and low temperature alarms, you can send commands: 0000,136,1,40.5,-10

Description: 1 is the serial number of the temperature sensor, 40.5°C is the high temperature alarm, and -10°C is the low temperature alarm.

3) Get the temperature value, you can send the command: 0000,137

Reply: 137, 1: 29.0, 2: 28.8

Description: 1 is the first temperature sensor with a temperature value of 29.0°C; 2 is the second temperature sensor with a temperature value of 28.8°C.

8.2.6 RFID Reader Installation

When the device is connected to an RFID card reader, it can prevent illegal starting of the vehicle. The wiring connection is as follows:

When the driver does not swipe the authorized card to start the vehicle, it is considered to be illegally started, the device will automatically disconnect the fuel supply and electricity, and the vehicle cannot be started.

For related parameter setting instructions, please refer to "iStartek GPS tracker Communication Protocol V1.3".

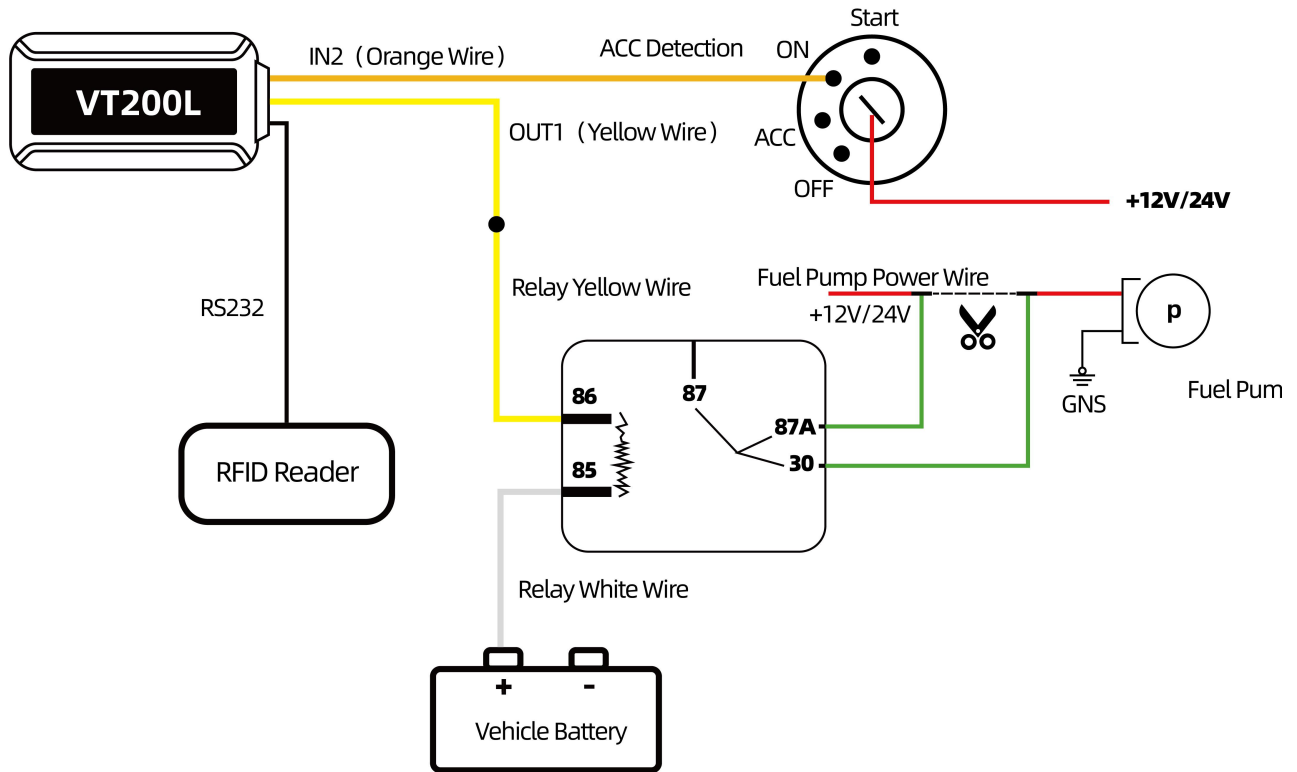

After connected wires as above, you can authorize the RFID card, delete the RFID card, and query the authorization status of the RFID card according to the SMS instructions.

Example: to authorize an RFID card, you can send SMS command: **0000,144,123456789,987654321**

Description: The authorization ID number is 123456789,987654321.

After authorization, set OUT1 to control vehicle fuel and electricity supply. When OUT1 is required to control the fuel and electricity supply, it is necessary to use the 212 command to set the 53 event to control OUT1. Swiping the card to control the fuel and electricity is a separate control logic, not controlled by the output mode set by 251 command.

Commands that can be sent: 0000, 212, 1, 1, 53

To delete the RFID card, you can send the SMS command: **0000,145,123456789,987654321**

Delete the ID number 123456789,987654321.

Description: To query the authorization status of the RFID card, you can send the SMS command:

0000,146,123456789,987654321

Query ID number 123456789,987654321,

SMS reply 146,123456789:1,987654321:1

Description: 1 means authorized (authorization status: 0 means not authorized, 1 means authorized).

8.2.7 iButton Installation

When the device is connected to an iButton, it can prevent illegal starting of the vehicle. The wiring connection is as follows:

When the driver does not swipe the authorized button to start the vehicle, it is considered to be illegally started, the device will automatically disconnect the fuel supply and electricity, and the vehicle cannot be started.

For related parameter setting instructions, please refer to "iStartek GPS tracker Communication Protocol V1.3".

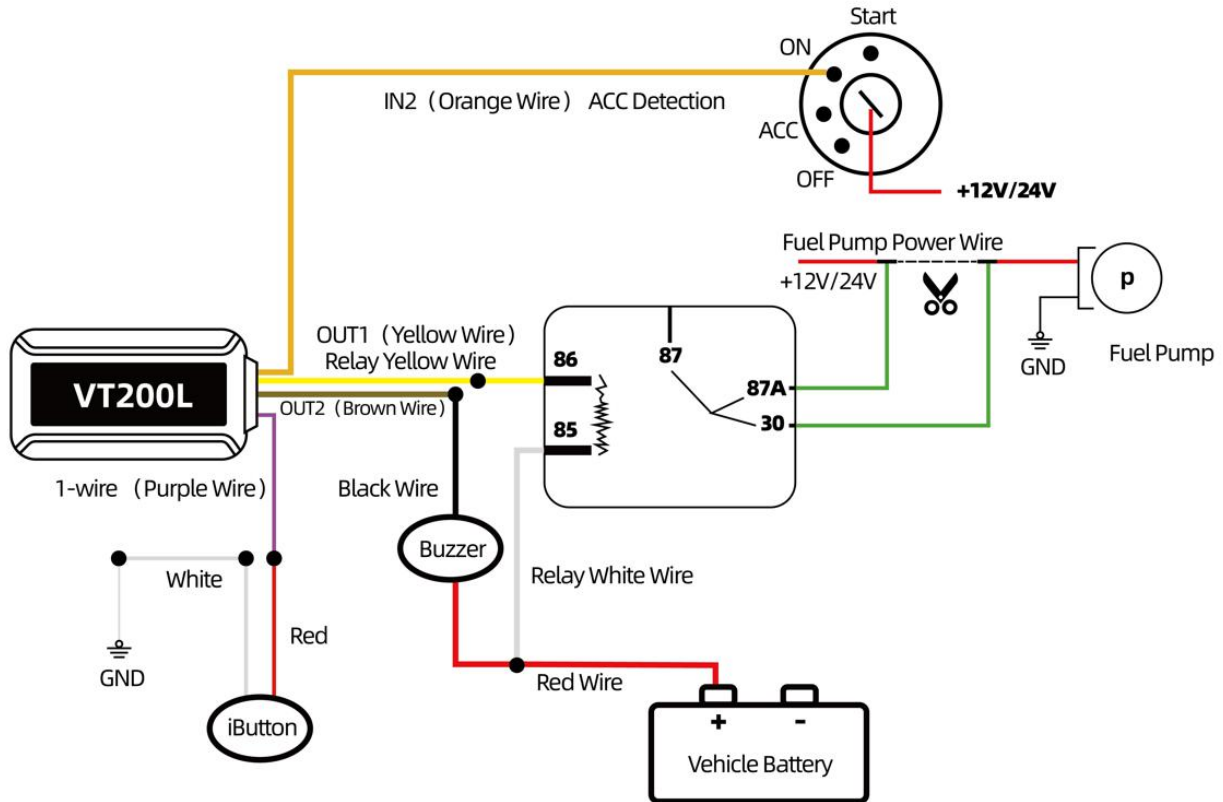

After connected wires as above, you can authorize the iButton ID, delete the iButton ID, and query the authorization status of the iButton ID according to the SMS instructions.

Example: to authorize an iButton ID, you can send SMS command: **0000,144,#00000A678C,#00000E4321F**

Description: The authorization ID number is 0x00000A678C,0x00000E4321F.

After authorization, set OUT1 to control vehicle fuel and electricity supply. When OUT1 is required to control the fuel and electricity supply, it is necessary to use the 212 command to set the 53 event to control OUT1. Swiping the button to control the fuel and electricity is a separate control logic, not controlled by the output mode set by 251 command.

Commands that can be sent: 0000, 212, 1, 1, 53

When use the ibutton function, Output2 is defaulted as the card swiping prompt tone. A beep sound will be heard when the iButton is swiped.

To delete the iButton ID, you can send the command: **0000,145,#00000A678C,#00000E4321F**

Delete the ID number 0x00000A678C,0x00000E4321F

Description: To query the authorization status of the iButton ID, you can send the command:

0000,146,#00000A678C,#00000E4321F

Query ID number 0x00000A678C,0x00000E4321F

SMS reply 146,#00000A678C:1,#00000E4321F:1

Description: 1 means authorized (authorization status: 0 means not authorized, 1 means authorized).

8.2.8 Ultrasonic Fuel Sensor Installation

The height measurement range of the ultrasonic fuel sensor is 0~100cm (0~250cm optional), and the corresponding voltage output range is 0~5V.

V200 L analog input connect to the ultrasonic fuel sensor, the green wire of the sensor is connected to the AD1 blue wire of the VT200-L or the IN3 gray wire (AD2).

Example: When the fuel is empty, the sensor output voltage is 0V. With a fuel tank height of 100cm as the standard, then fuel sensor output voltage is 5V when fuel is full.

If the height of the fuel tank is H_0 cm and the fuel tank is full of F liters, the fuel sensor output voltage is $V=H_0/20$ when the fuel is full.

Calculate the remaining fuel volume:

Percentage of fuel = $(AD/V)*100\%$

The fuel volume height is: $H=(AD/5)*100\text{cm}$

The remaining liters of fuel volume = $(AD/V)*F$ liters



After connected wires, can set the size of the fuel tank (length, width, height), sensor type (capacitive fuel sensor or ultrasonic fuel sensor), liters of fuel theft alarm, fuel theft time, low fuel alarm by Parameter Editor.

- 1) **Configuration by Parameter Editor:** Set the fuel tank name to Right Tank; Fuel tank type to ultrasonic fuel sensor; Fuel tank size, 1000mm in length, 500mm in width, and 1000mm in height; Set the fuel theft alarm to active when the fuel reduction exceeds 20 liters within 60 seconds; Set low fuel alarm to active when the fuel volume is less than 10 liters.

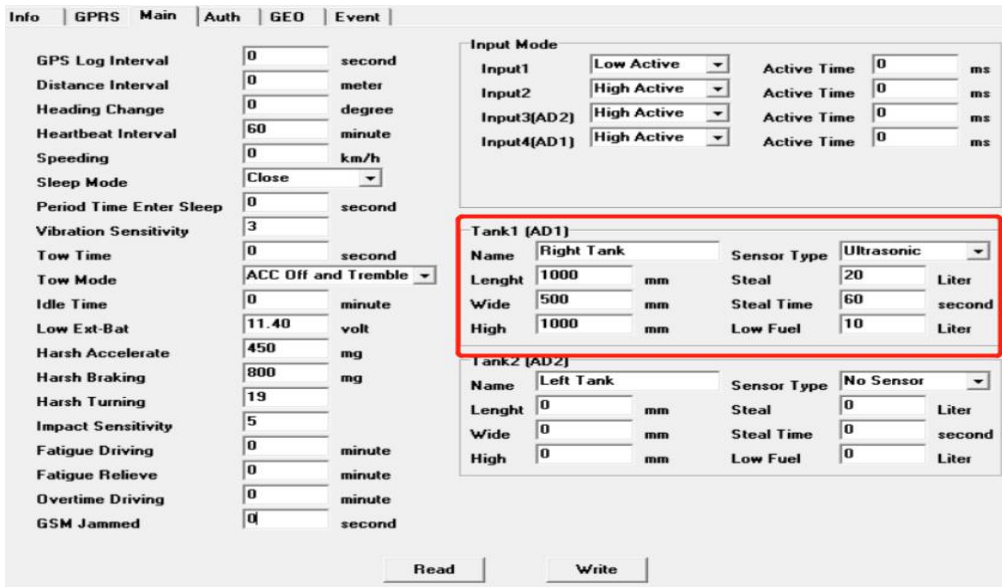

The screenshot shows a configuration window for a GPS tracker. On the left, there are various system settings like GPS Log Interval, Distance Interval, etc. On the right, there are input mode settings and two fuel tank configurations. The 'Tank1 (AD1)' section is highlighted with a red box. It shows the following parameters:

Tank1 (AD1)			
Name	Right Tank	Sensor Type	Ultrasonic
Length	1000 mm	Steal	20 Liter
Wide	500 mm	Steal Time	60 second
High	1000 mm	Low Fuel	10 Liter

The 'Tank2 (AD2)' section shows similar parameters but with 'No Sensor' selected and zero values for length, width, and high.

2) **Configuration by SMS Command:** Set fuel tank parameters through SMS commands **138, 139, 140, and 141**. For related parameter setting commands, please refer to "iStartek GPS tracker Communication Protocol V1.3".

Send above parameters by SMS commands:

Set fuel tank parameters, you can send commands: **0000,138,1,1000,500,1000**

Description: 1 is the serial number of the fuel tank. The length of the fuel tank is 1000mm, the width is 500mm, and the height is 1000mm.

Set the type of fuel sensor, you can send commands: **0000,139,1,1,Right Tank**

Description: The first "1" is for the serial number of the fuel tank, the second "1" is AD1 connected to ultrasonic fuel sensor, and Right Tank is the name of the fuel tank.

Set the fuel theft alarm, you can send commands: **0000,140,1,20,60**

Description: Set AD1 as the corresponding fuel tank, and the fuel theft alarm will be triggered when the fuel reduction exceeds 20 liters within 60 seconds.

Set low fuel alarm, you can send commands: **0000,141,1,10**

Description: Set AD1 as the corresponding fuel tank, and a low fuel alarm will be triggered when the fuel volume is less than 10 liters.

Note: The 138, 139, and 141 commands must be set to detect fuel alarms.

For example: GPRS data with a fuel tank height of 100cm and a full fuel of 50 liters

&&A147,021104023195429,000,0,,180106093046,A,22.646430,114.065730,8,0.9,54,86,76,326781,460|0|27B3|0EA7,27,0000000F,02,01,04E2|018C|01C8 |0000,1,0104B0,01013D|02813546\r\n

AD1 voltage is **0x01C8 (hexadecimal)=456 (decimal), AD1=456/100 (fixed value)=4.56V;**

AD2 voltage is **0x0000=0, AD2=0/100=0V;**

Fuel percentage=**(AD1/5)*100%=(4.56/5)*100%=91.2%**

Fuel height: **H=(AD1/5)*100cm=(4.56/5)*100cm =91.2 cm**

The remaining fuel volume in liters = **(AD1/5) * 50 liters = 45.6 liters**

8.2.9 OBD Reader Installation

When connect device with OBD reader, a customized firmware is required. Reading various data of the car can be customized.

For related parameter setting instructions, please refer to "iStartek GPS tracker Communication Protocol V1.3".

The wiring connection is as follows:



8.2.10 Speed limiter installation

A. When the car is ignition on and idling, use a multimeter to measure and record the voltage V_H of the gas pedal high-level signal line and the voltage value V_L of the low-level signal line, as shown in the figure below. (Note: The position and color of the gas pedal signal wire of different models may be different, subject to actual measurement)



B. Connect the A01 speed limiter to the vehicle power supply, and connect the yellow control wire to the ground wire, open the bottom cover of the speed limiter housing, and use a screwdriver to adjust the two variable resistors (clockwise to increase the voltage value, counterclockwise to decrease the voltage Value) so that the output voltage of the green signal wire is equal to the voltage value V_H , and the output voltage of the gray signal wire is equal to the voltage value V_L .

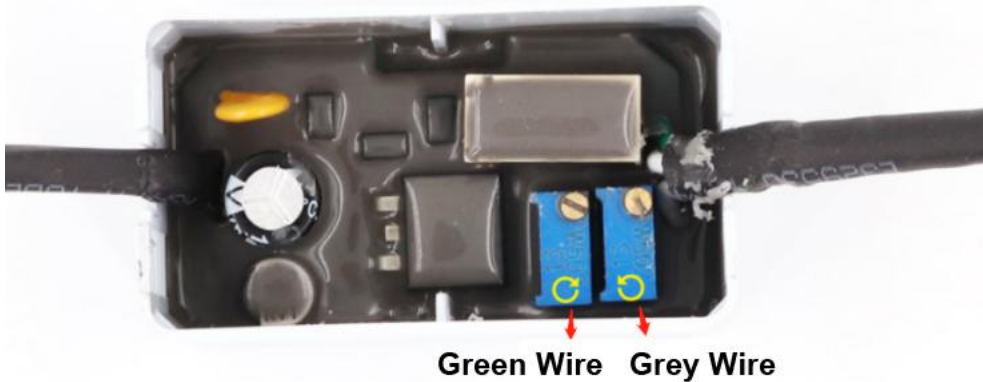

C. Cut off the gas pedal signal wire of the car, connect the GPS Tracker and speed limiter as shown in the figure below. (Note: The color of the gas pedal signal wire of different car models may be different. The following figure is only an example, and subject to the actual vehicle signal line)

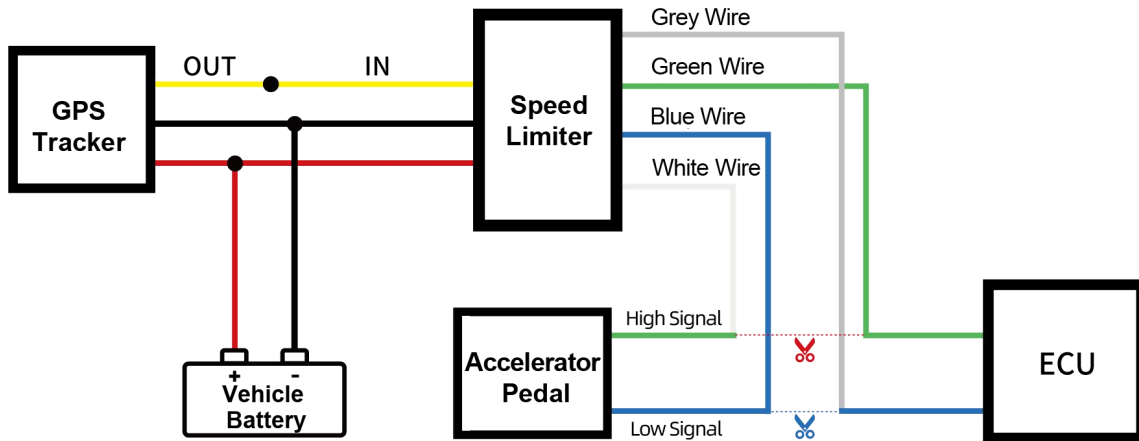

After the wires are connected, the speed limit value can be set through the parameter editor or SMS command:

1. Parameter editor settings: VT100 and VT200 series of product set as shown in the figure below:

Event	SMS Alarm Name	GPRS		Auth No.1		Auth No.2		Auth No.3		Output	
		1	2	sms	call moni	sms	call moni	sms	call moni	1	2
(0) Interval tracking	Interval	<input checked="" type="checkbox"/>	<input checked="" type="checkbox"/>	<input type="checkbox"/>	<input type="checkbox"/>	<input type="checkbox"/>	<input type="checkbox"/>	<input type="checkbox"/>	<input type="checkbox"/>	<input type="checkbox"/>	<input type="checkbox"/>
(1) Input1 active	SOS	<input checked="" type="checkbox"/>	<input checked="" type="checkbox"/>	<input type="checkbox"/>	<input type="checkbox"/>	<input type="checkbox"/>	<input type="checkbox"/>	<input type="checkbox"/>	<input type="checkbox"/>	<input type="checkbox"/>	<input type="checkbox"/>
(2) Input1 inactive	In1 Inactive	<input type="checkbox"/>	<input type="checkbox"/>	<input type="checkbox"/>	<input type="checkbox"/>	<input type="checkbox"/>	<input type="checkbox"/>	<input type="checkbox"/>	<input type="checkbox"/>	<input type="checkbox"/>	<input type="checkbox"/>
(3) Input2 active	Ignition On	<input checked="" type="checkbox"/>	<input checked="" type="checkbox"/>	<input type="checkbox"/>	<input type="checkbox"/>	<input type="checkbox"/>	<input type="checkbox"/>	<input type="checkbox"/>	<input type="checkbox"/>	<input type="checkbox"/>	<input type="checkbox"/>
(4) Input2 inactive	Ignition Off	<input checked="" type="checkbox"/>	<input checked="" type="checkbox"/>	<input type="checkbox"/>	<input type="checkbox"/>	<input type="checkbox"/>	<input type="checkbox"/>	<input type="checkbox"/>	<input type="checkbox"/>	<input type="checkbox"/>	<input type="checkbox"/>
(5) Input3 active	Door Open	<input checked="" type="checkbox"/>	<input checked="" type="checkbox"/>	<input type="checkbox"/>	<input type="checkbox"/>	<input type="checkbox"/>	<input type="checkbox"/>	<input type="checkbox"/>	<input type="checkbox"/>	<input type="checkbox"/>	<input type="checkbox"/>
(6) Input3 inactive	Door Close	<input type="checkbox"/>	<input type="checkbox"/>	<input type="checkbox"/>	<input type="checkbox"/>	<input type="checkbox"/>	<input type="checkbox"/>	<input type="checkbox"/>	<input type="checkbox"/>	<input type="checkbox"/>	<input type="checkbox"/>
(7) Input4 active	In4 Active	<input checked="" type="checkbox"/>	<input checked="" type="checkbox"/>	<input type="checkbox"/>	<input type="checkbox"/>	<input type="checkbox"/>	<input type="checkbox"/>	<input type="checkbox"/>	<input type="checkbox"/>	<input type="checkbox"/>	<input type="checkbox"/>
(8) Input4 inactive	In4 Inactive	<input type="checkbox"/>	<input type="checkbox"/>	<input type="checkbox"/>	<input type="checkbox"/>	<input type="checkbox"/>	<input type="checkbox"/>	<input type="checkbox"/>	<input type="checkbox"/>	<input type="checkbox"/>	<input type="checkbox"/>
(9) Input5 active	In5 Active	<input checked="" type="checkbox"/>	<input checked="" type="checkbox"/>	<input type="checkbox"/>	<input type="checkbox"/>	<input type="checkbox"/>	<input type="checkbox"/>	<input type="checkbox"/>	<input type="checkbox"/>	<input type="checkbox"/>	<input type="checkbox"/>
(10) Input5 inactive	In5 Inactive	<input type="checkbox"/>	<input type="checkbox"/>	<input type="checkbox"/>	<input type="checkbox"/>	<input type="checkbox"/>	<input type="checkbox"/>	<input type="checkbox"/>	<input type="checkbox"/>	<input type="checkbox"/>	<input type="checkbox"/>
(11) Input6 active	In6 Active	<input checked="" type="checkbox"/>	<input checked="" type="checkbox"/>	<input type="checkbox"/>	<input type="checkbox"/>	<input type="checkbox"/>	<input type="checkbox"/>	<input type="checkbox"/>	<input type="checkbox"/>	<input type="checkbox"/>	<input type="checkbox"/>
(12) Input6 inactive	In6 Inactive	<input type="checkbox"/>	<input type="checkbox"/>	<input type="checkbox"/>	<input type="checkbox"/>	<input type="checkbox"/>	<input type="checkbox"/>	<input type="checkbox"/>	<input type="checkbox"/>	<input type="checkbox"/>	<input type="checkbox"/>
(17) Ext-power low	Low Ext-Power	<input checked="" type="checkbox"/>	<input checked="" type="checkbox"/>	<input type="checkbox"/>	<input type="checkbox"/>	<input type="checkbox"/>	<input type="checkbox"/>	<input type="checkbox"/>	<input type="checkbox"/>	<input type="checkbox"/>	<input type="checkbox"/>
(18) Ext-power lost	Ext-Power Cut	<input checked="" type="checkbox"/>	<input checked="" type="checkbox"/>	<input type="checkbox"/>	<input type="checkbox"/>	<input type="checkbox"/>	<input type="checkbox"/>	<input type="checkbox"/>	<input type="checkbox"/>	<input type="checkbox"/>	<input type="checkbox"/>
(19) Ext-power connect	Ext-Power On	<input checked="" type="checkbox"/>	<input checked="" type="checkbox"/>	<input type="checkbox"/>	<input type="checkbox"/>	<input type="checkbox"/>	<input type="checkbox"/>	<input type="checkbox"/>	<input type="checkbox"/>	<input type="checkbox"/>	<input type="checkbox"/>
(20) Internal battery low	Low Battery	<input checked="" type="checkbox"/>	<input checked="" type="checkbox"/>	<input type="checkbox"/>	<input type="checkbox"/>	<input type="checkbox"/>	<input type="checkbox"/>	<input type="checkbox"/>	<input type="checkbox"/>	<input type="checkbox"/>	<input type="checkbox"/>
(21) GPS antenna cut	GPS Antenna Cut	<input checked="" type="checkbox"/>	<input checked="" type="checkbox"/>	<input type="checkbox"/>	<input type="checkbox"/>	<input type="checkbox"/>	<input type="checkbox"/>	<input type="checkbox"/>	<input type="checkbox"/>	<input type="checkbox"/>	<input type="checkbox"/>
(22) Speeding alarm	Speeding	<input checked="" type="checkbox"/>	<input checked="" type="checkbox"/>	<input type="checkbox"/>	<input type="checkbox"/>	<input type="checkbox"/>	<input type="checkbox"/>	<input type="checkbox"/>	<input type="checkbox"/>	<input checked="" type="checkbox"/>	<input type="checkbox"/>
(23) Enter sleep	Enter Sleep	<input checked="" type="checkbox"/>	<input checked="" type="checkbox"/>	<input type="checkbox"/>	<input type="checkbox"/>	<input type="checkbox"/>	<input type="checkbox"/>	<input type="checkbox"/>	<input type="checkbox"/>	<input type="checkbox"/>	<input type="checkbox"/>

GPS Log Interval: second

Distance Interval: meter

Heading Change: degree

Heartbeat Interval: minute

Speeding: km/h

Sleep Mode:

Period Time Enter Sleep: second

Vibration Sensitivity:

Tow Time: second

Tow Mode:

Idle Time: minute

Low Ext-Bat: volt

Harsh Accelerate: mg

Harsh Braking: mg

Harsh Turning:

Impact Sensitivity:

Fatigue Driving: minute

Fatigue Relieve: minute

Overtime Driving: minute

GSM Jammed: second

Car Type:



File Name	VT200-L User Manual	Ver.	1.1
Update	2021-4-10	Page	24 of 18

2. SMS command settings: VT100 and VT200 series of product send 123 commands and 212 commands, for example:

0000, 123, 60 Set the speed limit value to 60KM/H

0000,212,1,1,22 Set to trigger output 1 after exceeding the set speed value

If you have any other questions, please send an email to info@istartek.com, we are happy to serve you.