

File Name	VT900 User Manual	Version	1.3
Update	2019-03-6	Page	1 of 14

iStartek GPS Vehicle Tracker User Guide V1.3

VT900





File Name	VT900 User Manual	Version	1.3
Update	2019-03-6	Page	2 of 14

Content

1. Copyright and disclaimer.....	3
2. Product Overview.....	3
3. VT900 Functions.....	3
4. VT900 Characteristics.....	4
5. Hardware and Accessories.....	5
5.1 Standard Accessories.....	5
5.2 Optional Accessories.....	5
6. Product Appearance.....	5
7. Product Use.....	6
7.1 Charge.....	6
7.2 Insert SIM Card.....	6
7.3 Antenna Connection.....	6
7.4 VT900 Power on.....	7
7.5 Track by Phone.....	7
7.6 Track by SMS.....	8
7.7 Parameter configuration.....	8
7.8 Platform location tracking.....	9
8. Product Installation.....	9
8.1 Functions introduction for Inputs/ Ouptuts.....	9
8.2 RS232 port.....	10
8.3 GND Installation.....	10
8.4 Digital Inputs installation.....	10
8.5 Analog Input (AD1) installation.....	11
8.6 Output Control wire installation.....	12
8.7 Temperature sensor installation (customized).....	12
8.8 RFID Card Reader installation.....	13
8.9 iButton Installation (customized).....	13
8.10 Magnetic Card Reader installation (customized).....	14
8.11 Ultrasonic Fuel sensor installation.....	14



File Name	VT900 User Manual	Version	1.3
Update	2019-03-6	Page	3 of 14

1. Copyright and disclaimer

Copyright © 2018 iStartek. Shenzhen iStartek Technology Co., Ltd.

iStartek and  is a registered trademark of Shenzhen iStartek Technology Co., Ltd.

This user manual shall not be reproduced for any purpose or transmitted in any way without written authorization of iStartek company.

iStartek shall not be liable for any direct or indirect damages (included but not limited to economic losses, personal damage, loss of property and assets) caused by the use, non-use or improper use of this product or documentation.

2. Product overview

VT900 is a GPS/WCDMA based tracking device, specially developed and designed for vehicle real-time tracking and fleet management.

VT900 has an inbuilt GPS module to obtain accurate position data. This device utilizes its GSM/WCDMA capability to send position data to a specified mobile phone or server base for tracking and fleet management.

With internal memory, VT900 can store GPS coordinates when there is no GPRS/WCDMA connection, or at a specified interval requested by the user.

One optional feature of VT900 is that a RS232 port Can connect RFID card reader, magnetic card reader and other Accessories.

3. VT900 has the following functions and features:

- ✧ SMS and GPRS/WCDMA TCP/UDP Communication
- ✧ Track on Demand
- ✧ Track by Time Interval
- ✧ Track by Distance
- ✧ Heading change Report
- ✧ Show Location Directly on Mobile Phone
- ✧ SOS Alarm
- ✧ Power-cut Alarm
- ✧ Engine/ door on/ off status alarm
- ✧ Geo-fencing Alarm
- ✧ Speeding Alarm
- ✧ GPS Blind Area Alarm (in/out)
- ✧ Hash acceleration alarm
- ✧ Hash deceleration alarm
- ✧ Low Battery Alarm
- ✧ Low external power supply alarm
- ✧ Mileage Report

- ✧ 8MB Flash Memory
- ✧ OTA
- ✧ ACC ON/OFF Time Interval
- ✧ Remotely Engine Cut (Stop Engine)
- ✧ RFID Reader Optional
- ✧ iButton Optional
- ✧ Buzzer Optional
- ✧ Fuel sensor Optional
- ✧ Temperature Sensor Optional

4. VT900 Characteristics

Items	Specifications
Dimension	65 x 61 x 26mm
Weight	106g
Power supply	DC 9 - 36V/1.5A
Backup battery	500mAh/3.7V
Normal power consumption	65mA/h
Work time	33hours in power saving mode and 7.5 hours in normal mode
Operation temperature	-20°C to 55°C
Humidity	5% to 95%
GSM/UMTS Frequency	<p>VT900-T : UMTS/HSDPA: 850/2100MHz GSM/GPRS: 850/900/1800/1900MHz</p> <p>VT900-A : UMTS/HSDPA: 850/1900MHz GSM/GPRS: 850/900/1800/1900MHz</p> <p>VT900-E : UMTS/HSDPA: 900/2100MHz GSM/GPRS: 900/1800MHz</p>
GPS Sensitivity	-165dB
Location Accuracy	2.5 Meter
LED Indicator	2 LED lights to show GPS/GSM/WCDMA status
Antenna	External GSM/GPS Antenna
Flash Memory	8MB (16192 GPRS/WCDMA location data, 256 SMS)
Sensor	Vibration sensor
Inputs/Outputs	3 digital inputs (1 negative trigger, 2 positive trigger) 1 analog input (0~24V) 2 digital outputs

File Name	VT900 User Manual	Version	1.3
Update	2019-03-6	Page	5 of 14

	1 RS232 1 USB port
--	-----------------------

5. Hardware and Accessories

5.1 Standard Accessories



Main Unit



Power Cable



GPS Antenna



GSM Antenna

5.2 Optional Accessories



RFID Card Reader



RFID Tags



iButton Reader



iButton



Ultrasonic Fuel Sensor



Lever Type Fuel Sensor



Temperature Sensor



Relay



Magnetic Card Reader



USB Cable

6. Product Appearance

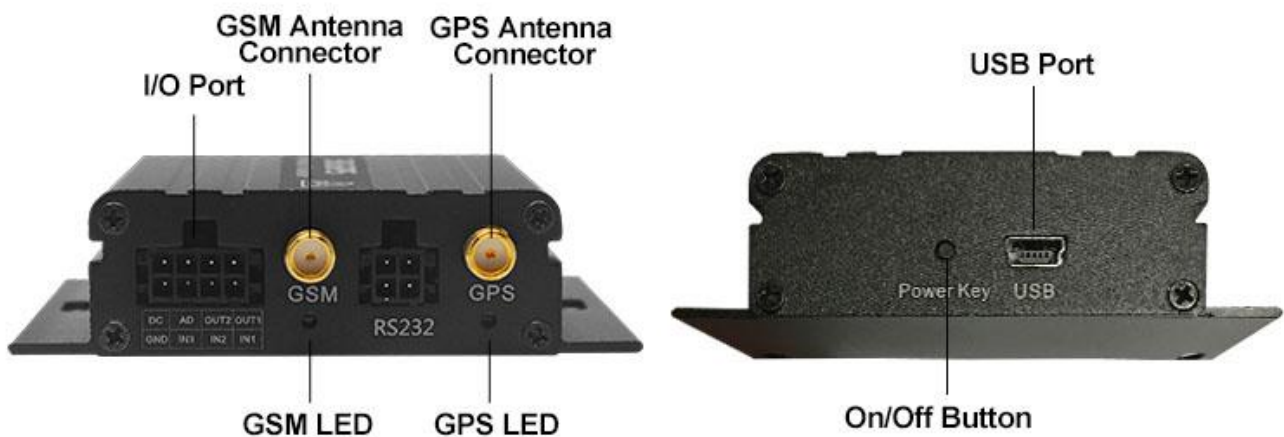

7. Product use

7.1 Charge

For the first time using the VT900, please connect the DC (positive) and GND (ground) to the 12V or 24V power supply for at least 2 hours to ensure sufficient power. After configuration and testing, install it on the vehicle.

7.2 Insert SIM Card

Device supports SIM cards of 2G and 3G networks;

Please ensure that the SIM card has sufficient balance, and has opened the GPRS function and obtained the correct APN of the SIM card;

Please make sure that the PIN lock function of the SIM card has been turned off;

If you need to use the call to reply to the location information function, please make sure that the SIM card has caller ID function;

- a. Make sure the device is turned off before installing the SIM. Unscrew the front baffle screw and take out the PCBA



- b. Insert SIM Card



- c. Fit on PCBA and screw on the screw

7.3 Antenna Connection

Connect GSM antenna on the SMA connector labeled "GSM" and connect the GPS antenna on the SMA connector labeled "GPS", also ensure that both antennas are tightened.

The GSM antenna can be hidden in any place away from the power supply and cannot be attached to the metal surface, otherwise it will affect the GSM signal strength.

GPS antenna is used to receive satellite signal in the sky and should be fixed to face the sky and can not be installed in a

place with metal shielding.



7.4 Turn on VT900

Long press the power button for 3-5 sec, or connect to the external power supply, VT900 will turn on.

LED operation status :

GPS (blue)	
On	Input is active
Off	Device Turn off or in sleeping mode
Flashing (every 0.1 sec)	GPS module is starting up or restarting
Flashing (0.1 sec on and 2.9 sec off)	VT900 Received GPS signal
Flashing (1 sec on every 2 secs)	No GPS signal
GSM (green)	
On	A call is coming in/a call is being made
Off	Device Turn off or in sleeping mode
Flashing (every 0.1 sec)	GPS module is starting up or restarting
Flashing (0.1 sec on and 2.9 sec off)	VT900 Received GSM signal
Flashing (1 sec on every 2 secs)	No GSM signal

7.5 Track by Phone

Make a missed call to the tracker and it will report its location by SMS with the following google link format, clicking on the link the location will be shown directly on your mobile phone.

SMS content description:

142161102222,Current! 20171123 15:53,A,0Km/h,<http://maps.google.com/?q=22.540103,114.082329>

Content	Instruction
142161102222	ID number
Current!	Alarm character, different alarm events have different alarm character
20171123 15:53	Date and time , YYYYMMDD hh:mm
A	GPS status, A is valid, V is invalid
0Km/h	GPS speed
http://maps.google.com/?q=22.540103,114.082329	Google link

File Name	VT900 User Manual	Version	1.3
Update	2019-03-6	Page	8 of 14

7.6 Track by SMS

Command: W*****,000

Description: Send this command to the tracker and you will receive an SMS with an http link. Click on the link and the location will be shown directly on your mobile phone using Google maps.

For SMS descriptions and more SMS commands please refer to iStartek SMS Protocol .

7.7 Parameter Configuration

Download and install USB cable driver PL2303_Prolific_Driver

Connect VT900 to the computer via USB cable. Operating Parameter_Editor configuration software and open the port.

Press the on/ off button for 1sec to make device enter Parameter Editor configuration state.



Parameter_Editor_V1.08
— □ ×

File Edit Help

Com
COM3 Close

Operation
Read All Write All Finish Initialize All

GPRS | SMS/Calling | Main Setting | GEO Fence

<p>GPRS Enable <input checked="" type="checkbox"/></p> <p>GPRS Type TCP</p> <p>Time Interval 3 *10s</p> <p>ACC Off Interval 0 *10s <input type="checkbox"/> Enable</p> <p>Device ID 112233445566</p> <p>APN CMNET</p> <p>APN Name </p> <p>APN Password </p> <p>IP/Domain Name istartracker.com</p> <p>Port 8011</p>	<p>Input Alarm(GPRS)</p> <p>Input1: <input checked="" type="checkbox"/> Active <input type="checkbox"/> Inactive</p> <p>Input2: <input checked="" type="checkbox"/> Active <input type="checkbox"/> Inactive</p> <p>Input3: <input checked="" type="checkbox"/> Active <input checked="" type="checkbox"/> Inactive</p> <p>Input4: <input type="checkbox"/> Active <input type="checkbox"/> Inactive</p> <p>Input5: <input type="checkbox"/> Active <input type="checkbox"/> Inactive</p>
--	--

Read Write

Connected Read All OK

For more parameters configuration, please refer to the user guide of Parameter Editor.

7.8 Platform location tracking

You can set server IP, Port and APN, GPRS interval by SMS commands 011, 012, 013, 014, or you can use Parameter_Editor software to configure related parameters.

8. Product installation

8.1. Functions introduction for Inputs/outputs



DC	AD	OUT2	OUT1
GND	IN3	IN2	IN1

PIN	Color	Function
DC	Red	DC In (power input). Input voltage: 9V~36V. 12V/24V suggested.
GND	Black	Ground
IN1	White	Digital input 1, negative trigger. Can be used to connect SOS button.
IN2	White	Digital input 2, positive trigger. Can be used to connect the starting door trigger signal line and detect the status of the door.
IN3	White	Digital input 3, positive trigger. Can be used to connect ACC and detect the ignition status of the car.
OUT1	Yellow	Output 1. Low level (0V) when the output is valid, open leakage output (OD) when it is invalid. The maximum withstand voltage of open leakage output (invalid) is 45 v. The maximum withstand current at low voltage is 500 ma. External relays can be connected to remotely cut off the oil line/engine power supply, etc.
OUT2	Yellow	Output 2. Low level (0V) when the output is valid, open leakage output (OD) when it is invalid. The maximum withstand voltage of open leakage output (invalid) is 45 v. The maximum withstand current at low voltage is 500 ma. It can be connected with external buzzer alarm, etc.
AD	Blue	10-digit analog input, effective input voltage value is 0-24v. Can be used to connect external sensor, such as fuel sensor, etc.

8.2 RS232 port

RS232 port can connect with RFID, magnetic card reader and other accessories.

1 DC 5V output	3 VT900 RX
2 GND	4 VT900 TX

8.3 GND installation

Connect respectively the power cable and GND to the positive pole and negative pole of the car battery to give Power supply :

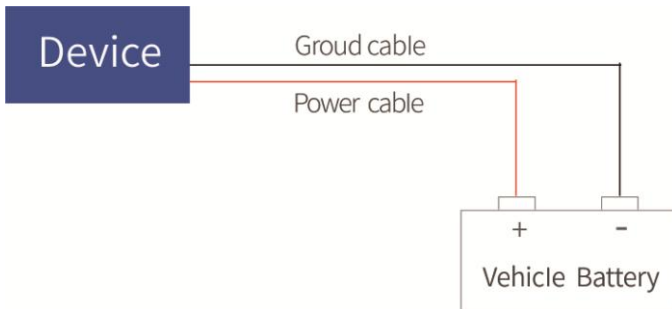

8.4 Digital inputs installation

Input3 can be connected to the ignition switch of the car to detect the ignition.
 Input1 or Input2 can be connected to the car door to detect the status of the door.

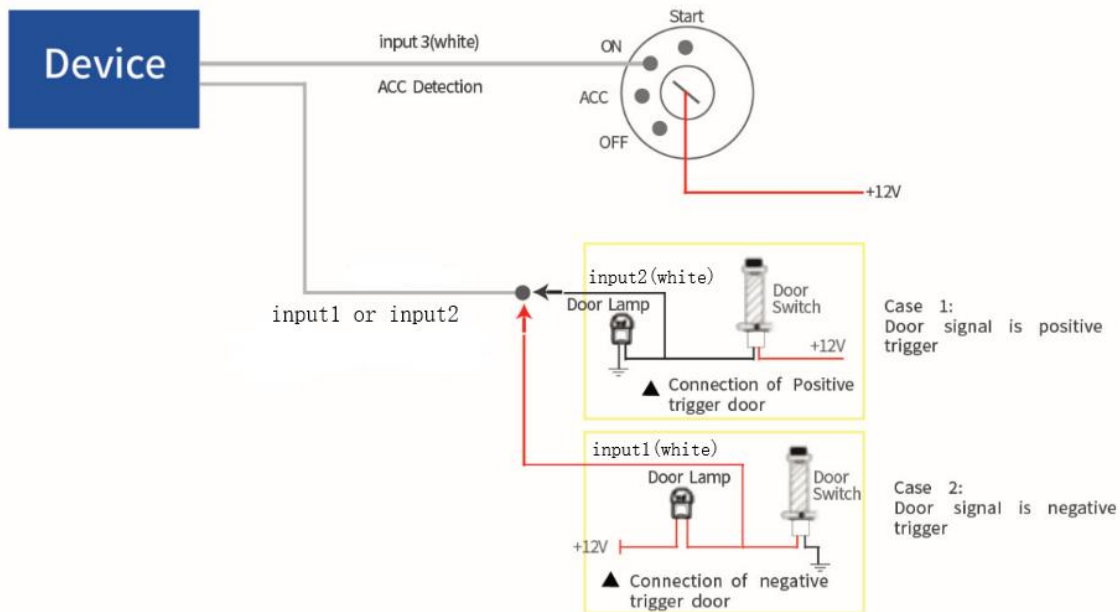

Input1 (VIL) can also be connected to PIN switch to detect the status of hood:



8.5 Analog Input (AD1) installation

Analog input range is 0-24v, it can be connected to the voltage output type sensor, such as fuel sensor.

Input voltage calculation formula : $\text{Input Voltage} = (\text{AD} * 24) / 1024$

For example, GPRS data is :

094506.000,A,2232.5412,N,11404.6919,E,0.00,,290709,,*12|1.7|110|0000|00AA,0000

AD = 0x00AA = 170

Input Voltage = $(\text{AD} * 24) / 1024 = (170 * 24) / 1024 = 3.984375\text{V}$.

For example:

Analog input connect with fuel sensor , Yellow-green wire of the sensor is connected to the blue wire of VT900.

Output voltage of the sensor is 0V when the fuel tank is empty, Output voltage of the sensor is 5V when the fuel Tank is full.

Calculate the percentage of Remaining oil :

Oil percentage = $\frac{((\text{AD} * 24) / 1024) / 5}{1} * 100\%$

Calculate liters of Remaining oil :

Percentage * Total liters

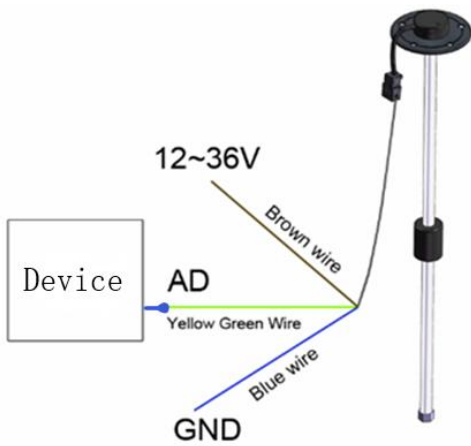

8.6 Output Control wire installation

Output can be connected with relay to cut off oil/electricity and control the vehicle. Can also be connected to a buzzer.

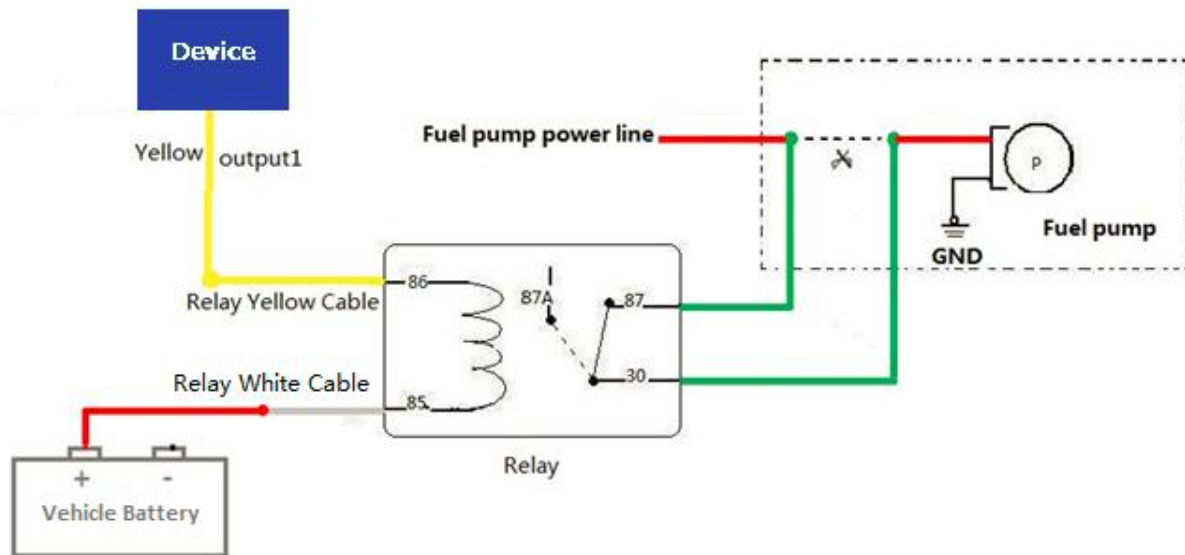

8.7 Temperature sensor installation (customized)

Customized hardware and software versions are required when the device connect the temperature sensor.

Need to customize input2 to 1-wire cable, change the AD line to the 5V voltage supply of the temperature sensor, the wiring diagram as follows :

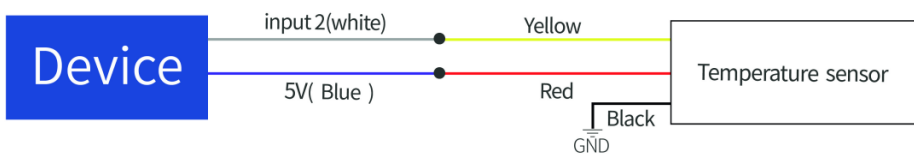

8.8 RFID Card Reader installation

Device connect with RFID Reader can prevent driver start vehicle illegally , the wiring diagram as follows :

When the driver starts the vehicle without swiping the authorized card, it is considered to start illegally, and the device will automatically disconnect the oil and electricity and fail to start the vehicle.

Related sms commands please refer to iStartek SMS protocol and iStartek GPRS Protocol.

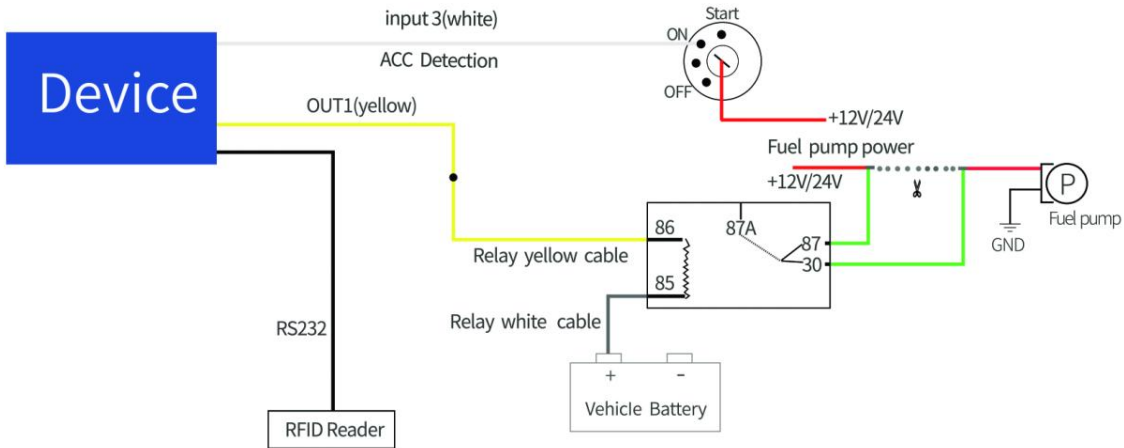

8.9 iButton Installation (customized)

Customized hardware and software versions are required, need to customize input2 to 1-wire cable.

Device connect with ibutton can prevent driver start vehicle illegally , the wiring diagram as follows :

When the driver starts the vehicle without swiping the authorized card, it is considered to start illegally, and the device will automatically disconnect the oil and electricity and fail to start the vehicle.

For related parameter setting instructions, please refer to iStartek SMS protocol and iStartek GPRS Protocol.

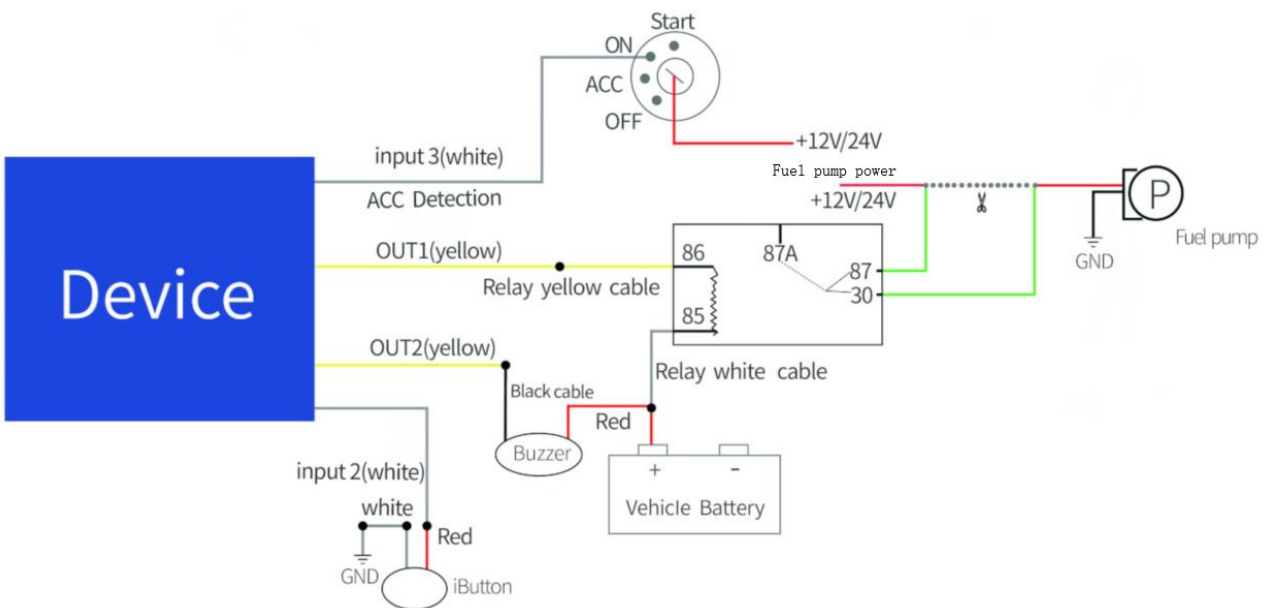

8.10 Magnetic Card Reader installation (customized)

Customize the software version for DLT.

For related parameter setting instructions, please refer to iStartek SMS protocol and iStartek GPRS Protocol.

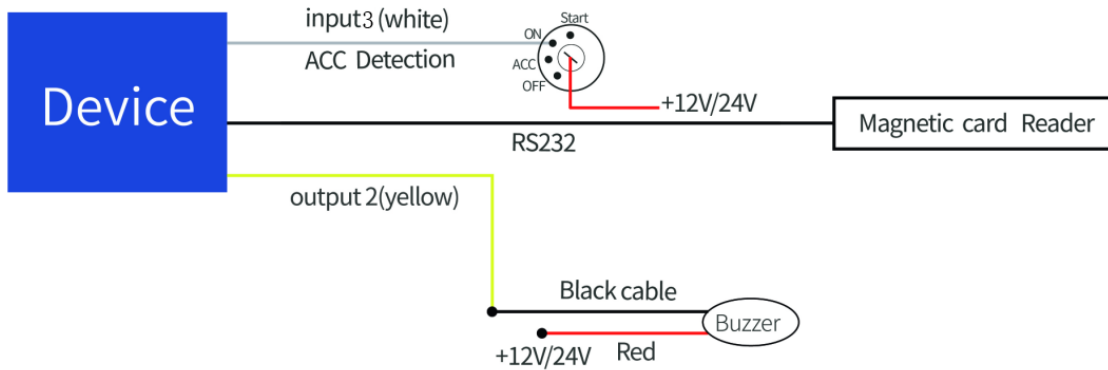

8.11 Ultrasonic fuel sensor installation

The height measurement range of ultrasonic fuel sensor is fixed at 0~100cm, and the corresponding output voltage range is 0~5V.

Formula to calculate oil height : $h = \frac{(AD * 24)}{1024} * 100\text{cm}$

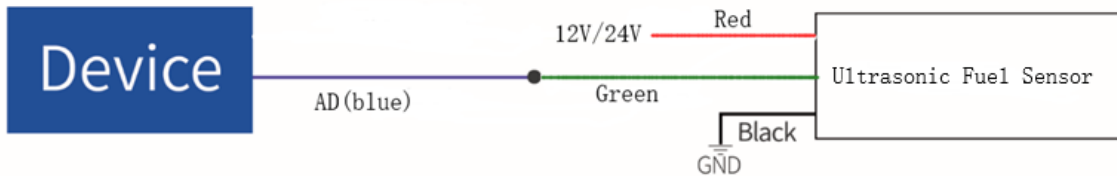

If you have any other questions, please send an email to info@istartek.com, we are happy to serve you.